

# TM 5-4120-364-13

## OPERATOR, ORGANIZATIONAL AND DIRECT SUPPORT MAINTENANCE MANUAL

---

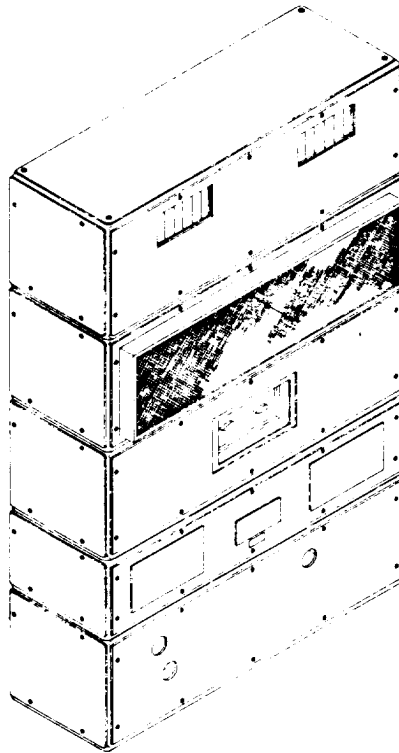

**AIR CONDITIONER, MULTI-PACKAGE,  
TYPE I CONFIGURATION, 18,000 BTU/HR,  
120/208 VOLT, 50/60 HZ, 3-PHASE,  
5-HIGH STACK CONFIGURATION**

**NSN 4120-01-077-6931**

---

HEADQUARTERS, DEPARTMENT OF THE ARMY

17 OCTOBER 1980

**TABLE OF  
CONTENTS  
PAGE iii**

**EQUIPMENT  
DESCRIPTION  
PAGE 1-1**

**OPERATING  
INSTRUCTIONS  
PAGE 2-1**

**ORGANIZATIONAL  
MAINTENANCE  
INSTRUCTIONS  
PAGE 3-1**

**DIRECT  
SUPPORT  
MAINTENANCE  
PAGE 4-1**

**SUBJECT  
INDEX  
INDEX 1**



CHANGE  
NO. 3

HEADQUARTERS  
DEPARTMENT OF THE ARMY  
WASHINGTON D. C., 1 JULY 1992

Operator, Organizational and Direct Support Maintenance Manual

**AIR CONDITIONER, MULTI-PACKAGE, TYPE I CONFIGURATION,  
18,000 BTU/HR, 120/208 VOLT, 50/60 HZ, 3-PHASE,  
5-HIGH STACK CONFIGURATION  
NSN 4120-01-477-6931**

Approved for public release; Distribution is unlimited

TM 5-4120-364-13, 17 October 1980 is changed as follows:

1. Remove and insert pages as indicated below. New or changed text material is indicated by a vertical bar in the margin. An illustration change is indicated by a miniature pointing hand.

Remove pages	Insert pages
4-5 and 4-6 - - - - -	4-5 and 4-6
4-9 and 4-10	4-6.1 /(4-6.2 blank)
C-5/( C-6 blank)	4-9 and 4-10
	C-5 and C-6

2. Retain this sheet in front of manual for reference purposes.

By Order of the Secretary of the Army:

Official:

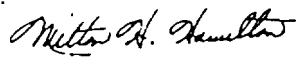
  
MILTON H, HAMILTON  
*Administrative Assistant to the  
Secretary of the Army*  
01591

GORDON R. SULLIVAN  
*General, United States Army  
Chief of Staff*

DISTRIBUTION:

To be distributed in accordance with DA Form 12-25E, (qty rqr block no. 0103)



CHANGE

NO. 2

HEADQUARTERS  
DEPARTMENT OF THE ARMY  
WASHINGTON, D.C., 20 NOVEMBER 1990

Operator, Organizational and Direct Support Maintenance Manual

**AIR CONDITIONER, MULTI-PACKAGE, TYPE I CONFIGURATION,  
18,000 BTU/HR, 120/208 VOLT, 50/60 HZ, 3-PHASE,  
5-HIGH STACK CONFIGURATION  
NSN 4120-01-077-6931**

Approved for public release; distribution is unlimited

TM 54120-364-13, 17 October 1980 is changed as follows:

1. Remove and insert pages as indicated below. New or changed text material is indicated by a vertical bar in the margin, An illustration change is indicated by a miniature pointing hand.

Remove pages

Insert pages

2-3 and 2-4

2-3 and 2-4

2. Retain this sheet in front of manual for reference purposes,

**By Order of the Secretary of the Army:**

**CARL E. VUONO**

*General, United States Army  
Chief of Staff*

**Official:**

**THOMAS F. SIKORA**

*Brigadier General, United States Army  
The Adjutant General*

**DISTRIBUTION:**

To be distributed in accordance with DA Form 12-25E, (qty rqr block no. 0103).



CHANGE

No. 1

HEADQUARTERS  
DEPARTMENT OF THE ARMY  
WASHINGTON, D.C., 26 March 1987

Operator, Organizational and  
Direct Support Maintenance Manual

AIR CONDITIONER, MULTI-PACKAGE,  
TYPE I CONFIGURATION, 18,000 BTU/HR,  
120/208 VOLT, 50/60 HZ, 3-PHASE,  
5-HIGH STACK CONFIGURATION  
NSN 4120-01-077-6931

TM 5-4120-364-13, 17 October 1980, is changed as follows:

1. Remove and insert pages as indicated below. New or changed text material is indicated by a vertical bar in the margin. An illustration change is indicated by a miniature pointing hand.

Remove pages

i / ii  
1-1 and 1-2  
3-19 and 3-20  
- - -  
B-3 and B-4

Insert pges

i / ii  
1-1 and 1-2  
3-19 and 3-20  
3-20.1/3-20.2  
B-3 and B-4

2. Retain this sheet in front of manual for reference purposes.

By Order of the Secretary of the Army:

**JOHN A. WICKHAM, JR.**  
*General, United States Army*  
*Chief of Staff*

Official:

**R. L. DILWORTH**  
*Brigadier General, United States Army*  
*The Adjutant General*

DISTRIBUTION:

To be distributed in accordance with DA Form 12-31, Operator, Organizational, Direct Support and General Support Maintenance Requirements for Air Conditioner, Multi-Package, Type I Configuration, 18,000 BTU/HR, 120/208V, 50/60 HZ, 3PH (TM18K-120/208-3-60) (TM 5-4120-364 Series)





WARNING

Always disconnect electrical power from the air conditioner before starting any work on it. Ground any points of high potential.

When testing for refrigerant leaks with a halide torch, be sure the area is well ventilated. When the torch comes in contact with the refrigerant, phosgene gas is formed. Phosgene gas has the odor of new mown hay and can be deadly.

Caution should be exercised with fluorocarbon refrigerant gas as they can displace oxygen and thereby cause suffocation.

Personnel with a history or other evidence of cardiac rhythm disturbances may be at increased risk of inducing further alterations of their cardiac rhythm as a result of exposure to fluorocarbon refrigerant gases. Such individuals should be evaluated by local medical authorities before working in environments where potential refrigerant gas exposure may occur.

When using compressed air for blowing and cleaning, air hose pressure must not exceed 30 psig, and individuals must wear eye protection equipment.



OPERATOR, ORGANIZATIONAL AND DIRECT SUPPORT  
MAINTENANCE MANUAL

Air Conditioner, Multi-Purpose, Type I  
Configuration, 18,000 BTU/HR, 120/208  
Volt, 50/60 Hz, 3-Phase, 5-High Stack  
Configuration

Model TM-18K-120/208-3-60  
NSN 4120-01-077-6931

**REPORTING ERRORS AND RECOMMENDING IMPROVEMENTS**

You can help improve this manual. If you find any mistake or if you know of away to improve the procedures, please let us know. Mail your letter, DA Form 2028 (Recommended Changes to Publications and Blank Forms), or DA Form 2028-2 located in the back of this manual direct to: Commander, U. S. Army Troop Support Command, ATTN: AMSTR-MPS, 4300 Goodfellow Boulevard, St. Louis, MO 63120-1798. A reply will be furnished directly to you.

		Page
CHAPTER 1	INTRODUCTION. . . . .	1-1
Section I	General. . . . .	1-1
Section II	Equipment Description. . . . .	1-1
Section 111	Technical Principles of Operation . . . . .	1-2
CHAPTER 2	OPERATING INSTRUCTIONS. . . . .	2-1
Section I	Description and Use of Operator's Controls and Indicators . . . . .	2-1
Section II	Preventive Maintenance Checks and Services (PMCS). . . . .	2-1
Section III	Operation Under Usual Conditions . . . . .	2-3
Section IV	Operation Under Unusual Conditions . . . . .	2-3
CHAPTER 3	ORGANIZATIONAL MAINTENANCE INSTRUCTIONS. . . . .	3-1
Section I	Repair Parts, Special Tools, TMDE, and Support Equipment . . . . .	3-1
Section II	Service Upon Receipt . . . . .	3-1
Section III	Preventive Maintenance Checks and Services (PMCS) . . . . .	3-3
Section IV	Troubleshooting . . . . .	3-3
Section V	Maintenance Procedures . . . . .	3-7
CHAPTER 4	DIRECT SUPPORT MAINTENANCE INSTRUCTIONS. . . . .	4-1
Section I	Repair Parts, Special Tools, TMDE, and Support Equipment . . . . .	4-1
Section II	Troubleshooting . . . . .	4-1
Section III	Maintenance Procedures . . . . .	4-1
APPENDIX A	REFERENCES . . . . .	A-1
APPENDIX B	COMPONENTS OF END ITEM LIST . . . . .	B-1
APPENDIX C	MAINTENANCE ALLOCATION CHART . . . . .	C-1
APPENDIX D	EXPENDABLE SUPPLIES AND MATERIALS LIST . . . . .	0-1
APPENDIX E	ADDITIONAL AUTHORIZATION LIST . . . . .	N/A
	SUBJECT INDEX. . . . .	INDEX 1



## CHAPTER 1

## INTRODUCTION

## Section I. General

## 1-1. SCOPE.

Type of Manual: Operator, Organizational and Direct Support Maintenance.

Model Number and Equipment Name: TM-18K-120/208-3-60 - Air Conditioner, Multi-purpose, 18,000 BTU/HR.

Purpose of Equipment: The air conditioner can be used in temporary buildings, shelters, mobile vans and trailers. The unit accomplishes three functions; cooling, dehumidification and ventilation.

## 1-2. MAINTENANCE FORMS AND RECORDS.

Department of the Army forms and procedures used for equipment maintenance will be those prescribed by DA PAM 738-750, The Army Maintenance Management System (TAMMS).

## 1-3. REPORTING EQUIPMENT IMPROVEMENT RECOMMENDATIONS (EIR's).

If your air conditioner needs improvements, let us know. Send us an EIR. You, the user, are the only one who can tell us what you don't like about your equipment. Let us know why you don't like the design. Tell us why a procedure is hard to perform. Put it on an SF 368 (Quality Deficiency Report). Mail it to us at U. S. Army Troop Support Command, ATTN: AMSTR-QX, 4300 Goodfellow Boulevard, St. Louis, MO 63120-1798. We'll send you a reply.

## 1-4. HAND RECEIPT.

Hand receipts for Components of End Item (COEI), Basic Issue Item (BII), and Additional Authorization List (AAL) item are published in a Hand Receipt manual, TM 5-4120-364-13-HR. This manual is published to aid in property accountability and is available through: Commander, U.S. Army Publication Center, 2800 Eastern Boulevard, Baltimore, MD 21220-2896.

## Section II. Equipment Description

## 1-5. EQUIPMENT PURPOSE.

The tactical design of the 18,000 BTU/HR air conditioner allows it to be used in many different type installations. These include temporary buildings and shelters, mobile vans and trailers. The unit accomplishes three functions; cooling (air conditioning), dehumidification, and ventilation.

## 1-6. CAPABILITIES AND FEATURES.

The air conditioner is semi-portable and has a capacity of 18,000 BTU/HR. The unit may be operated on 120 or 208 volts, 3-phase, 50/60 Hz power. It is shipped wired

for 208 volt, 3-phase, 50/60 Hz power. It may be converted for use on 120 volt, 3-phase, 50/60 Hz power by changing the heater elements, adding an electrical jumper, and reconnecting certain leads (see electrical wiring diagram, figure 3-2). For cooling, the unit may be operated from an internal or external thermostat.

1-7. LOCATION AND DESCRIPTION OF MAJOR COMPONENTS.

Figures 1-1 and 1-2 show the location of the major sections and gives a description of the major components of the air conditioner.

1-8. DIFFERENCE BETWEEN MODELS.

This manual was prepared for the Tiernay Manufacturing Model TM-18K-120/208-3-60. There are no differences between models.

1-9. PERFORMANCE DATA.

Electrical Requirements:	120/208 volts, 50/60 Hz, 3-Phase
Capacity:	18,000 BTU/HR
Refrigerant Capacity:	13 pounds 8 ounces of refrigerant Specification BB-F-1421, Type 12
Cabinet Dimensions:	Length: 20 inches (50cm) Width: 46 inches (115cm) Height: 70 inches (175cm) Weight: 596 pounds (268.2kg)

Section III. Technical Principles of Operation

1-10. PRINCIPLES OF OPERATION.

a. General. The air conditioner is in a vertical configuration consisting of five sections bolted together as shown in figure 1-1. The five sections, from top to bottom consist of the following: Evaporator Fan Section, Evaporator Coil Section, Condenser Fan Section, Condenser Coil Section, and the Compressor Section.

b. Evaporator Fan Section. The evaporator fan section houses the evaporator fan motor which drives two squirrel cage fans, The evaporator fans draw air through an air filter, over the evaporator coil mounted in the evaporator coil section, and exhaust it into the conditioned area.

c. Evaporator Coil Section. The evaporator coil section houses the evaporator coil, air filter, expansion valve, suction line shutoff valve and the liquid line shutoff valve. Air from the conditioned area is drawn through the air filter and over the coil by the evaporator fans mounted in the evaporator fan section. Heat is absorbed from the air passing over the evaporator coil by the refrigerant passing through the coil. This actions serves to cool the air as it flows through the evaporator coil.

d. Condenser Fan Section. The condenser fan section houses the condenser fan motor which drives two squirrel cage fans identical to those contained in the

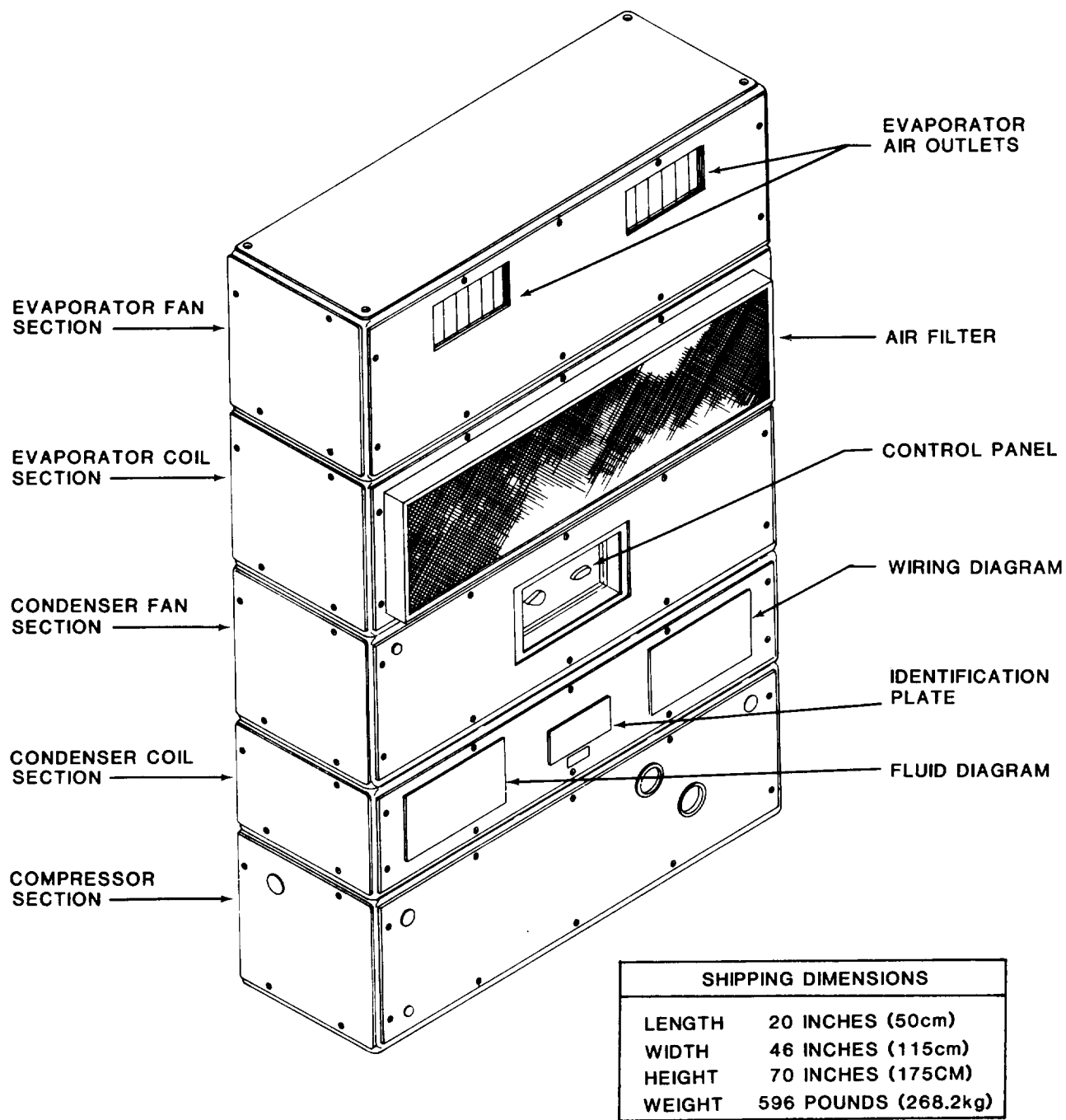

TS5-4 120-364-13/1-1

Figure 1-1. Three-quarter view of air conditioner

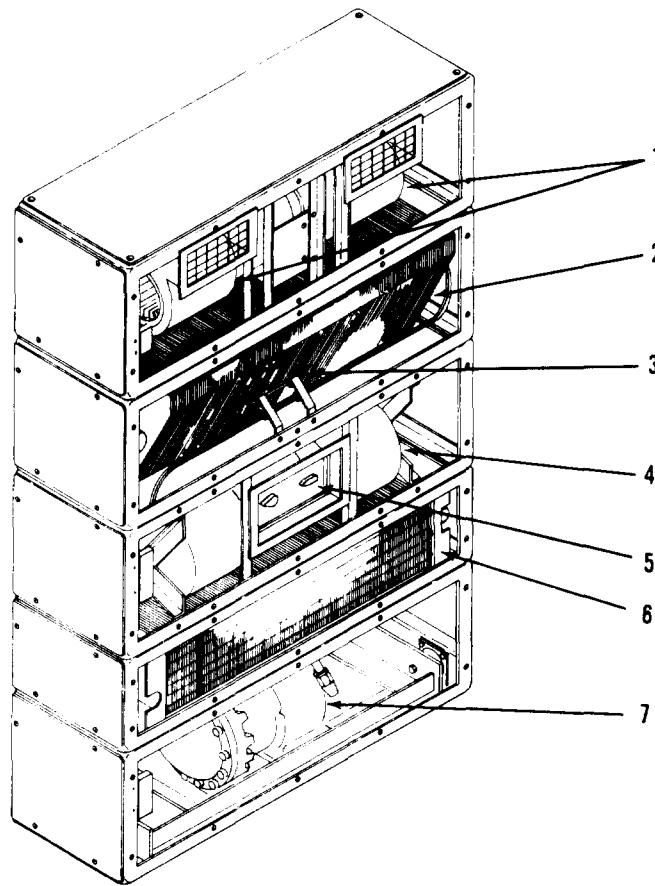

**EVAPORATOR FANS (1).** The evaporator fans draw air through an air filter, over the evaporator coil mounted in the evaporator section, and exhaust it into the conditioned area.

**EVAPORATOR COIL (2).** Heat is absorbed from the air passing over the evaporator coil by refrigerant passing through it. This action serves to cool the air as it flows through the evaporator coil.

**TEMPERATURE BULB (3).** Senses air temperature over the evaporator coil to maintain an even temperature of cooling air into the conditioned area.

**CONDENSER FANS (4).** The fans draw ambient air through the compressor section, over the condenser coil and exhaust it to the outside.

**CONTROL PANEL (5).** The control panel contains the manual thermostat and selector switch for controlling cooling air temperature and mode of operation.

**CONDENSER COIL (6).** Air drawn through the condenser coil by the condenser fans cools the refrigerant.

**MOTOR COMPRESSOR (7).** Semi-hermetic, two-piston electric motor driven compressor is used for pumping refrigerant through the system.

TS5-4120-364-13/1-2

**Figure 1-2. Location and description of major components**



evaporator fan section. A refrigerant sight glass and a filter drier are also contained in this section. The fans draw ambient (outside) air through the compressor section, over the condenser coil mounted in the condenser coil section, and exhaust it to the outside. The sight glass provides a visual indication of the refrigerant charge when the unit is operating. The filter drier removes foreign matter from the liquid refrigerant as it passes through it.

e. Condenser Coil Section. The condenser coil is located in this section. Ambient (outside) air is drawn from the compressor section by the condenser fans into and through the condenser coil. This action serves to change the refrigerant from a gaseous vapor state into a liquid state.

f. Compressor Section. The compressor section at the bottom of the five stack configuration, houses the motor compressor, magnetic starter and the high pressure cutout switch. The high pressure cutout switch stops the unit if the compressor discharge pressure raises above 280 psig. Ambient (outside) air is drawn into and through the compressor section by the condenser fans mounted in the condenser fan section.



CHAPTER 2

OPERATING INSTRUCTIONS

Section I. Description and Use of Operator's Controls and Indicators

2-1. GENERAL.

The description and use of the operator's controls and indicators is shown in figure 2-1.

Section II. Preventive Maintenance Checks and Services (PMCS)

2-2. GENERAL.

The preventive maintenance checks and services to be performed on this equipment are given in table 2-1.

- a. Before you operate. Perform your before (B) PMCS.
- b. While you operate. Perform your during (D) PMCS.
- c. If your air conditioner fails to operate, report it to Organizational Maintenance.

**Table 2-1. Operator/Crew Preventive Maintenance Checks and Services**

Perform weekly as well as before operations PMCS if:  
 (1) You are the assigned operator and have not operated the item since the last weekly.  
 (2) You are operating the item for the first time.

NOTE

If the equipment must be kept in continuous operation, check and service only those items that can be checked and serviced without disturbing operation. Make the complete checks and services when the equipment can be shut down.

Item No.	Interval					Item to be Inspected	Procedure	For readiness reporting, equipment is not ready/available if:
	B	D	A	W	M			
1	●					Air Filter	Check for cleanliness.	Clogged air filter restricting air flow.
2		●				General Maintenance	Be alert for unusual noises or improper operation. If either condition is detected, notify organizational maintenance.	

OPERATOR'S CONTROLS

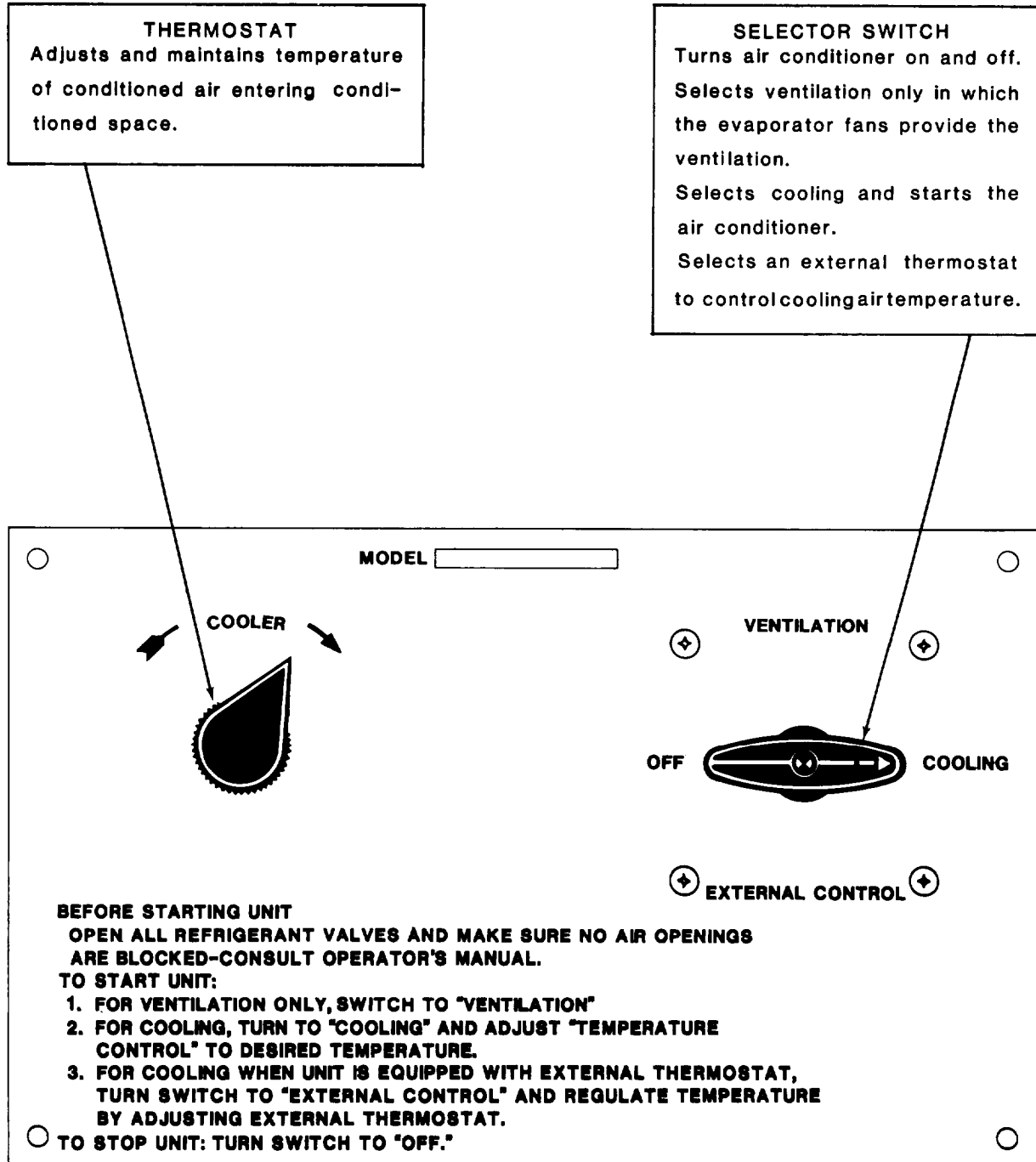

Figure 2-1. Operator's controls and Indicators TS5-4120-364-13/2-1

### Section III. Operation Under Usual Conditions

#### 2-3. GENERAL.

a. The instructions in this section are for the information and guidance of personnel responsible for the operation of the air conditioner.

b. The operator must know how to perform every operation of which the air conditioner is capable. This section gives instructions on starting and stopping the air conditioner, basic motions of the air conditioner, and on coordinating basic motions to perform specific tasks for which the equipment is designed.

c. Although the air conditioner is normally used for mechanically cooling the control space automatically, it may also be used to ventilate only. Care should be taken to insure that doors to the conditioned space close with a good seal against the ambient (outside) air. frequent door opening will impose an abnormal load on the air conditioning unit, preventing normal on and off cycles.

d. The operator must be observant at all times, particularly concerning unusual sounds that would indicate malfunctioning of the air conditioner. When unusual sounds occur, stop operation and report to organizational maintenance.

#### 2-4. OPERATION.

##### a. Starting.

(1) Refer to paragraph 2-2 and perform the daily preventive maintenance checks and services.

(2) Refer to figure 2-1 and start the air conditioner.

(3) The coolest setting of the thermostat should correspond to a temperature of approximately 60°F (18°C) in the conditioned air space. After several hours of operation at this setting, the thermostat may be set back from the extreme cooling position to attain whatever temperature above 60°F (18°C) is desired in the conditioned air space.

(4) For operation when the unit is equipped with an external thermostat, turn the selector switch to "EXTERNAL CONTROL" and the temperature will be controlled by the setting of the external thermostate.

(5) For ventilation only, turn the selector switch to "VENTILATION". In this mode, only the evaporator fans will operate.

b. Stopping. Refer to figure 2-1 and turn the selector switch to "OFF".

### Section IV. Operation Under Unusual Conditions

#### 2-5. OPERATION IN EXTREME COLD.

a. The air conditioner is designed to operate on the ceding cycle without forming frost or ice on the evaporator coil at an ambient (outside) temperature as low as 60°F (18°C).

b. If cooling air is desired at lower ambient (outside) temperatures, set the selector switch knob to the "VENTILATION" position to operate the blowers only.

2-6. OPERATION IN EXTREME HEAT.

**NOTE**

Unit preventive Maintenance Checks and Services (PMCS) should be performed at daily intervals.

a. General. The air conditioner is designed to operate in temperatures up to 120°F (49°C). Extra care should be taken to minimize the cooling load when operating in extreme high temperatures.

b. Protection.

(1) Check all openings in the enclosure, especially doors and windows, to be sure they are tightly closed. Limit in and out traffic if possible.

(2) When appropriate, use shades or awnings to shut out direct rays of the sun.

(3) When possible, limit the use of electric lights and other heat producing equipment-

(4) Limit the amount of hot, outside air introduced through the fresh air damper to that essential for ventilation.

**NOTE**

Weatherstripping, the installation of storm doors, and windows, if appropriate, and insulation of surfaces exposed to the outside is recommended when operating in extremely high temperatures for extended periods.

c. Cleaning.

(1) Clean outside grilles, coils, filters, and mist eliminator more frequently.

2-7. OPERATION IN DUSTY OR SANDY CONDITIONS.

**NOTE**

Unit Preventive Maintenance Checks and Services (PMCS) should be performed at daily intervals.

a. General. Dusty and sandy conditions can seriously reduce the efficiency of the air conditioner by clogging the air filter, mist eliminator, and coils. This will cause a restriction in the volume of airflow. Accumulation of dust or sand in the condenser coil and/or in the compressor compartment may cause overheating of the refrigeration system. Dust or sand may also clog the condensate trap and water drain lines.

**CAUTION**

Never operate the air conditioner without having the air filters in place.

b. Protection.

(1) Shield the air conditioner from dust as much as possible.

(2) Take advantage of any natural barriers which offer protection.

(3) Limit the amount of dusty or sandy outside air introduced through the fresh air damper.

(4) Roll down and secure the fabric cover on the back of the cabinet during periods of shutdown.

c. Cleaning.

(1) Keep the air conditioner as clean as possible.

(2) Pay particular attention to the outside grilles, condenser, filters, mist eliminator, louvers, and electrical components.

(3) In extreme conditions, daily cleaning of condenser, filters, and outside grilles may be necessary.

2-8. OPERATION UNDER RAINY OR HUMID CONDITIONS.

The air conditioner control panel must be protected to prevent direct contact with rain or heavy moisture.

2-9. OPERATION IN SALT WATER AREAS.

a. Exposure to salt water and air may cause corrosion of exposed metal surfaces.

b. Wash down the exterior of the unit with clean fresh water at frequent intervals. Take care not to damage electrical components with water.

c. Inspect the unit daily and clean the evaporator and condenser coils and air filter as often as required to maintain proper operation.

\* U.S. GOVERNMENT PRINTING OFFICE: 1991 554-123/20264

**PIN: 047288-002**

## CHAPTER 3

## ORGANIZATIONAL MAINTENANCE INSTRUCTIONS

**Section I. Repair Parts, Special Tools, TMDE, and Support Equipment**

## 3-1. COMMON TOOLS AND EQUIPMENT.

For authorized common tools and equipment, refer to the Modified Table of Organizational and Equipment (MTOE) applicable to your unit.

## 3-2. SPECIAL TOOLS, TMDE, AND SUPPORT EQUIPMENT.

There are no special tools, TMDE, or support equipment required to perform Organizational Maintenance on the air conditioner.

## 3-3. REPAIR PARTS.

Repair parts are listed and illustrated in the Repair Parts and Special Tools List TM 5-4120-364-23P covering Organizational Maintenance of this equipment.

**Section II. Service Upon Receipt**

## 3-4. ASSEMBLY AND PREPARATION FOR USE.

a. Unpackaging.

- (1) Open wooden crate or container and remove air conditioner.
- (2) Remove any barrier material revering the air conditioner. Be sure to remove any protective covering which may be over the air intake or exhaust grills and air filters.
- (3) If air conditioner is attached to a wooden skid, remove from skid.

b. Assembly. There are no assembly procedures, however, the air conditioner should be inspected after receipt as follows:

- (1) Remove the front, rear and end panels from all sections and inspect the air conditioner for physical damage to components and for oil leaks from the rotor compressor.
- (2) Use available leak detector over the entire unit to inspect for refrigerant leaks. Manually turn the fans to see that they turn freely with no rubbing or binding.
- (3) Check that all valves with the exception of the charging valve are open (see figure 3-1).

c. Installation.

(1) The air conditioner should be mounted level and in the proper alignment with the shelter wall. The evaporator air outlet and return should not be restricted by equipment within the shelter. The condenser air blower should not be restricted by grills or covers. Adequate space shall be provided at the front and sides of the unit for the removal of panels for service and maintenance.

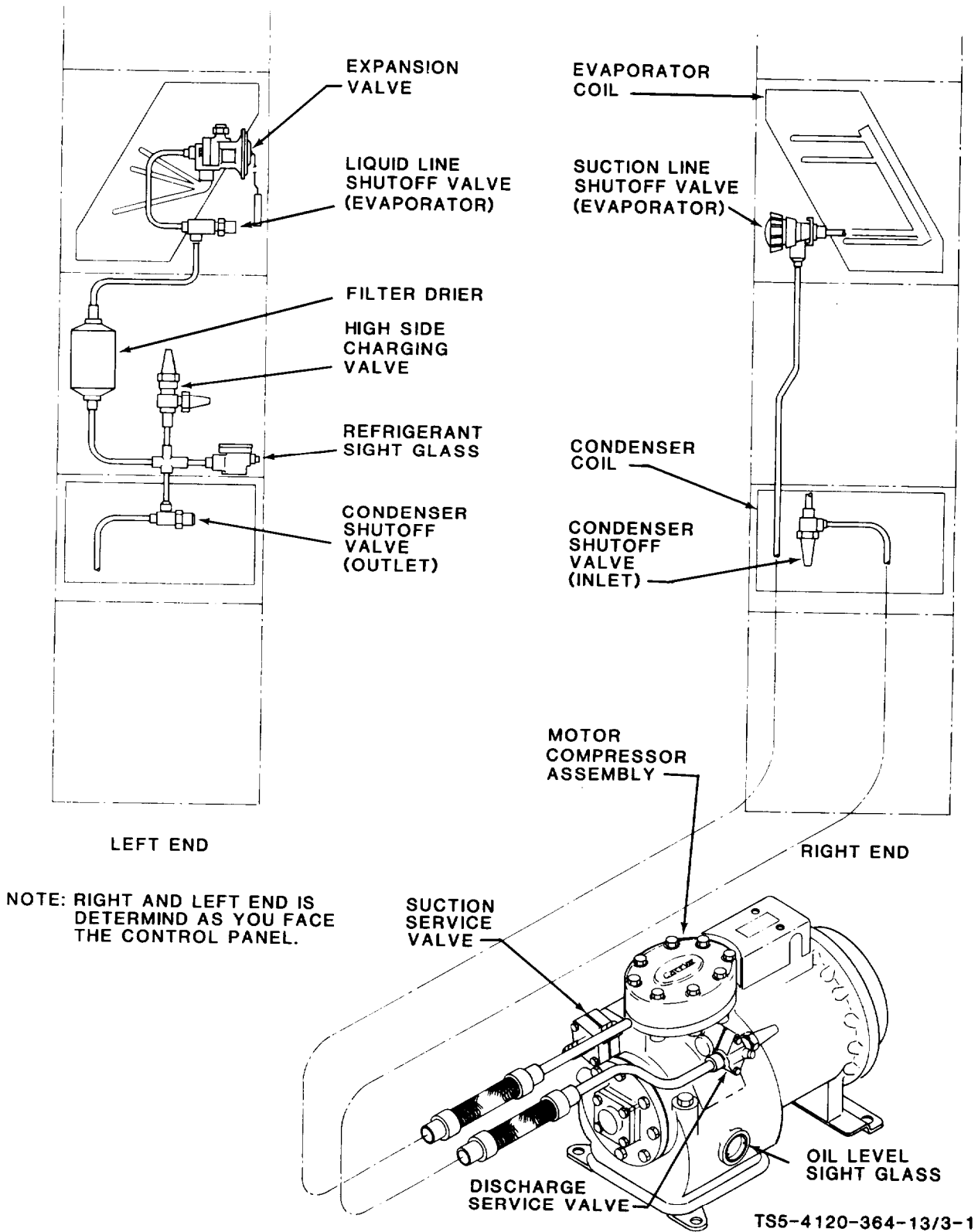

Figure 3-1. Location and functional names of valves



(2) Position the unit on the shelter wall for alignment of duct openings. Secure the unit to the wall by drilling holes in the back cover in alignment with the holes in the corners of the frame and install 5/16 inch bolts of the proper length.

(3) The unit is shipped for 208 volt, 3-phase, 50/60 Hz power. Connect a power source capable of delivering 208 volt, 3-phase, 50/60 Hz power to the connector on the rear panel of the compressor section. The unit may be converted to operate on 120 volt, 3-phase, 50/60 Hz power by changing the heater elements, adding a jumper and reconnecting certain leads as shown in the wiring diagram, figure 3-2.

3-5. PREPARATION FOR MOVEMENT.

a. Limited Movement. For movement to a short distance involving limited handling, it is necessary only to detach the air conditioner from the shelter and disconnect the power cable.

b. Extensive Movement. Pump down refrigerant in accordance with paragraph 4-6. Close all valves (see figure 3-1). Detach air conditioner from the shelter and disconnect the power source cable. Seal all openings in the cabinet with barrier material and sealing tape, Cover the entire cabinet with a protective barrier material.

Section III. Preventive Maintenance Checks and Services (PMCS)

3-6. GENERAL. Organizational Preventive Maintenance Checks and Services (PMCS) are contained in table 3-1.

a. If your equipment fails to operate, troubleshoot with proper equipment. Report any deficiencies using the proper forms, see TM 38-750.

b. Equipment is Not Ready/Available If: column. This column shall contain the criteria that will cause the equipment to be classified as not ready/available for readiness reporting purposes. An entry in this column will:

- (1) Identify conditions that make the equipment not ready/available for readiness reporting purposes.
- (2) Deny use of the equipment until corrective maintenance has been performed.

Section IV. Troubleshooting

3-7. TROUBLESHOOTING TABLE.

a. The troubleshooting table (table 3-2) list the most common malfunctions which you may find during the operation or maintenance of the air conditioner or its components. You should perform the test/inspections and corrective actions in the order listed.

b. This manual can not list all malfunctions that may occur, however, all tests or inspections and corrective actions are listed for most cannon malfunctions. If a malfunction is not listed, or is not corrected by listed corrective action, notify your supervisor.

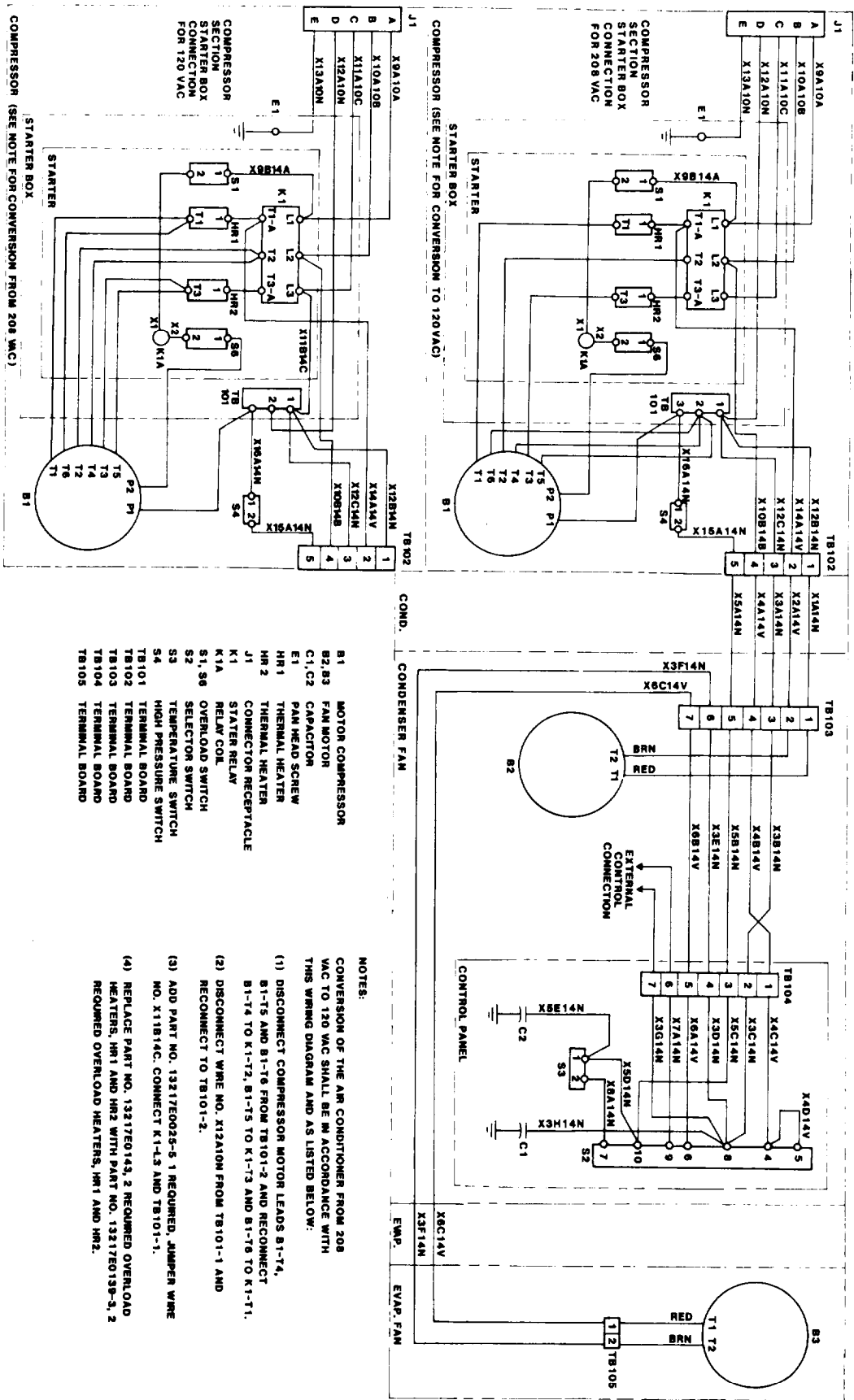

Figure 3-2. Electrical wiring diagram

TS5-4120-364-13/3-2

**Table 3-1. Organizational Preventive Maintenance Checks and Services**

B-Before D-During		A-After W-Weekly			M-Monthly			
Item No.	Interval					Item to be Inspected	Procedure	For readiness reporting, equipment is not ready/available if:
	B	D	A	W	M			
1				●		Compressor Sight Glass	Check oil level indicated by sight glass. Report low oil level to direct support maintenance.	Low oil level
2				●		Air Filter	Check for cleanliness.	Clogged air filter restricting air flow
3				●		Refrigerant Sight Glass	Check for bubbling or fogging. Report to direct support maintenance if either of these conditions exists.	Low refrigerant level
4					●	Air Conditioner	Visually inspect entire unit for cracks, breaks, and loose or missing hardware.	
5					●	Refrigerant System	Assure that refrigerant hoses and tubing are free of leakage, abrasion, tearing, kinking, etc. Report all defects to direct support maintenance	
6				●		Condenser and Evaporator Coils	Check Coil fins for dirt or other foreign matter which would restrict air flow	

**Table 3-2. Organizational Troubleshooting**

---

MALFUNCTION

TEST OR INSPECTION

CORRECTIVE ACTION

---

1. AIR CONDITIONER FAILS TO START

Step 1. Controls not properly set.

Set controls for starting.

Step 2. Power supply leads loose or not connected.

Check leads and tighten or connect leads as required.

2. AIR CONDITIONER NOISY DURING OPERATION

Step 1. Panels loose.

Tighten fasteners or replace defective fasteners as required.  
See figure 3-4 to replace fasteners.

Step 2. Loose component.

Tighten component.

3. INSUFFICIENT COOLING

Step 1. Thermostat improperly set.

Set thermostat for cooler operation.

Step 2. One or more shutoff valve(s) not open.

Refer to figure 3-1 and open suction line shutoff valve(s).

4. NO COOL AIR DISCHARGE

Step 1. Selector switch in wrong position.

Set selector switch for cooling.

Step 2. Thermostat improperly set.

Set thermostat for cooling.

Step 3. Air filter is dirty or clogged.

Refer to figure 3-8 remove and clean air filter.

**Table 3-2. Organizational Troubleshooting (continued)**

## MALFUNCTION

## TEST OR INSPECTION

## CORRECTIVE ACTION

Step 4. High pressure cutout switch tripped.

Reset high pressure cutout switch.

Step 5. Thermal overload switch tripped.

Allow rotor to cool and reset itself.

## 5. EXCESSIVE COOLING.

Step 1. Thermostat set for too cool operation.

Reset thermostat for temperature desired,

## Section V. Maintenance Procedures

## 3-8. GENERAL.

The entire air conditioning unit is enclosed in single unit frames with removable panels for easy access to components. These frames are bolted together to form a stacked vertical unit. For purposes of maintenance, the unit is covered by sections beginning at the top of the unit with the evaporator fan section, then the evaporator coil section, etc., ending with the bottom section which is the compressor section.

## 3-9. EVAPORATOR FAN SECTION.

a. Covers, Panels and Frame.

(1) Removal. Remove the covers and panels by turning the fasteners one-quarter turn counterclockwise. (See figure 3-3).

(2) Cleaning. Clean all parts with a damp cloth and dry thoroughly.

(3) Inspection.

(a) Inspect covers and panels for dents or other damage.

(b) Inspect fasteners and receptacles for security of attachment.

(c) Inspect gaskets for wear.

(d) Inspect insulation for security of attachment and for condition.

(4) Repair.

(a) Replace defective covers and panels.

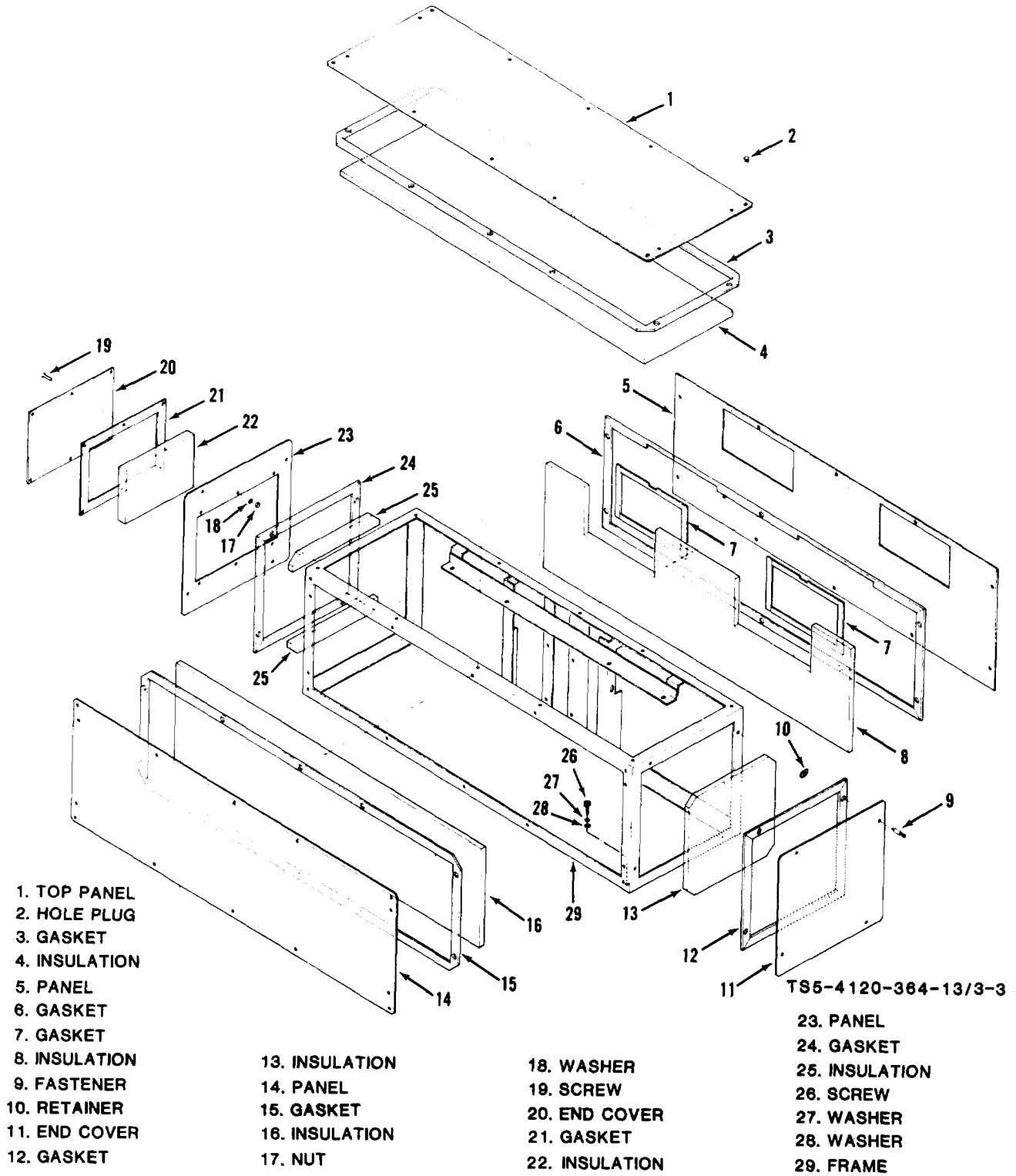

Figure 3-3. Evaporator fan section, covers, panels and frame

- (b) Replace defective fasteners. (See figure 3-4).
- (c) Replace defective gaskets. New gaskets are installed by removing the strip from the gasket adhesive backing and pressing the gasket in place.
- (d) Glue loose or new insulation to the panels with adhesive.
- (e) Install panels and secure by turning the fasteners one-quarter turn clockwise.

b. Fan Housings and Fans. The evaporator fan assembly consists of a dual squirrel cage type fan and housings powered by a 1/3 HP, 120 volt, single phase 50/60 Hz electric rotor. The motor is equipped with permanently lubricated ball bearings and an overload protector which will reset itself automatically after cooling.

(1) Removal.

(a) Refer to figure 3-3 and remove front, rear and end panels from the evaporator fan section by turning fasteners (9) one-quarter turn counterclockwise.

(b) Remove screws (18, figure 3-5), washers (19) and ring (20) from housing (26).

TO INSTALL FASTENER, INSERT FASTENER THROUGH PANEL AND SLIDE SELF LOCKING RETAINER OVER FASTENER.

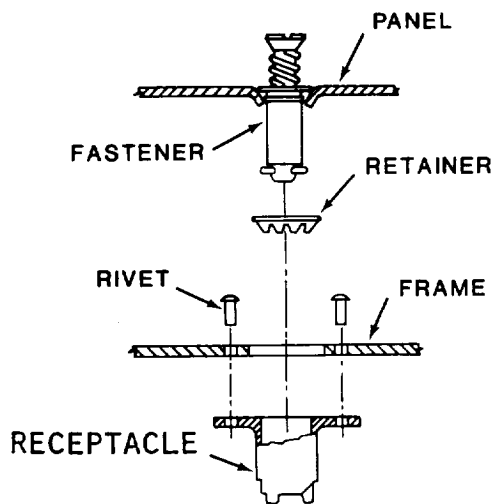

TM5-4120-364-13/3-4

**Figure 3-4. Panel fastener and receptacle installation**

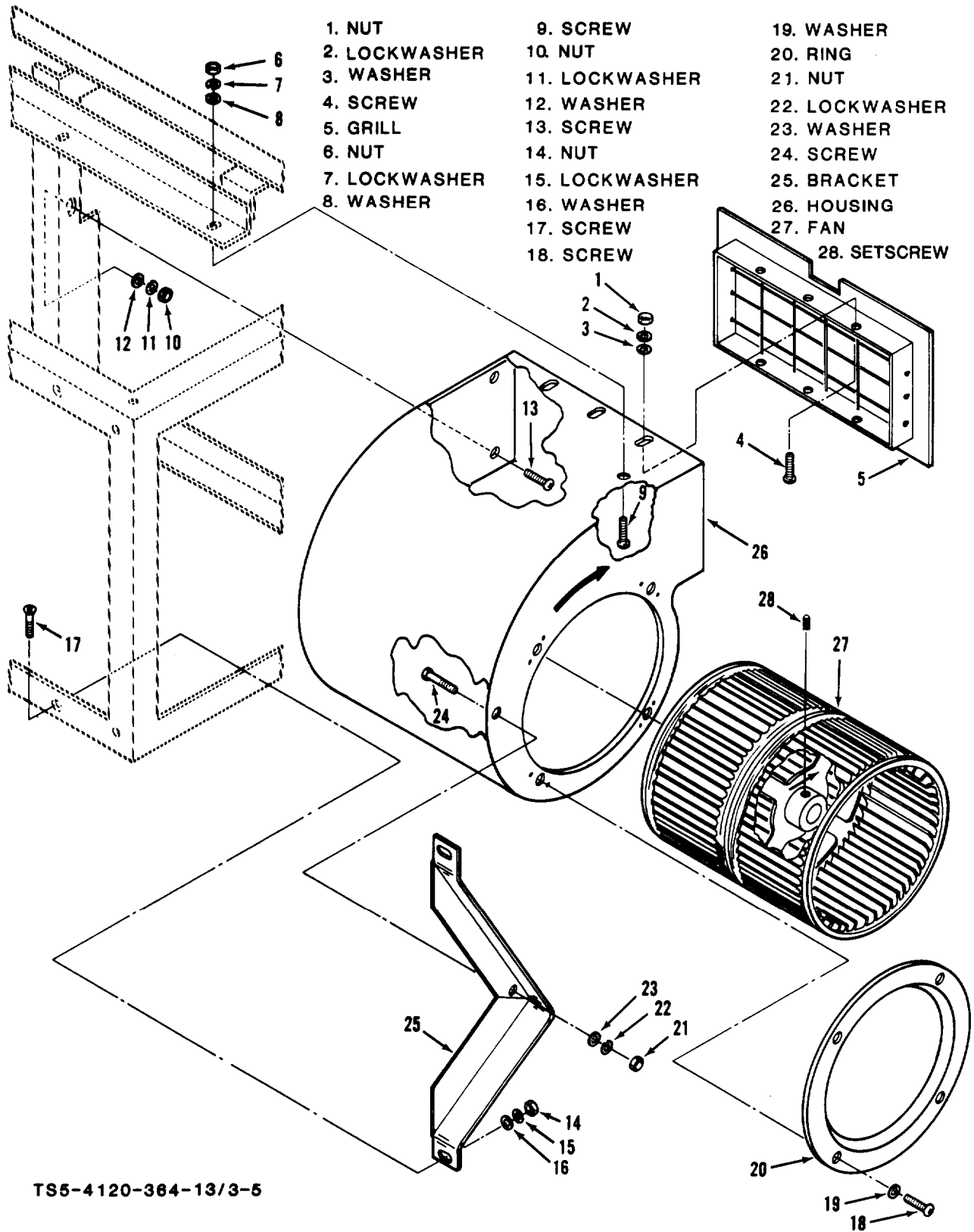

Figure 3-5. Evaporator fan section, fan housings and fans



(c) Loosen setscrew (28) in fan (27) and remove fan from motor shaft.

(d) Remove nuts (6, 10, 21), washers (7, 11, 22, 8, 12, 23) and screws (9, 13, 24), then remove housing (26) from frame.

(e) If replacement of grill (5) is required, remove nuts (1), washers (2, 3) , screws (4) and grill (5).

(2) Inspection. Inspect fan, fan housings and grill for evidence of damage which would impair serviceability.

(3) Repair. Repair of the fan housings and fans shall be by replacement of the defective component.

(4) Replace.

(a) If grill (5) is to be replaced, place grill into housing (26) and secure with screws (4), washers (3, 2) and nut (1).

(b) Place housing in frame and secure with screws (24, 13, 9), washers (23, 22, 12, 11, 7, 8) and nuts (21, 10, 6).

(c) Match direction of fan rotation arrow with arrow on fan housing and slide fan (27) over motor shaft and into housing (26). Make sure that fan clears housing and secure fan to motor shaft by tightening setscrew (28) in fan bushing.

(d) Attach ring (20) to housing (26) with screws (18) and washers (19).

(e) Refer to figure 3-3 and attach front, rear and end panels to evaporator fan section by turning fasteners (9) one-quarter turn clockwise.

c. Fan Motor.

(1) Removal.

(a) Refer to figure 3-3 and remove front, rear and end panels from evaporator fan section by turning fasteners (9) one-quarter turn Counterclockwise.

(b) Remove screws (18, figure 3-5), washers (19) and ring (20) from housing (26). Remove this ring from both housings on each side of rotor.

(c) Loosen setscrew (28) in fan (27), and remove fan from motor shaft. Remove fans from both sides of motor.

(d) Remove nuts (6, 10, 21), washers (8, 12, 23) and screws (9, 13, 24), then remove housings (26) from frame.

**WARNING**

Disconnect the power leads to the air conditioner before removing the fan rotor.

(e) Tag and disconnect motor leads from terminal board (14, figure 3-6) and ground wire (3) from frame,

(f) Remove nut (5), lockwasher (6) and bolt (7) and remove fan motor (9) from base (8) and frame.

(2) Inspect. Inspect fan rotor for loose wire connections, frayed or burned wires or other evidence of damage which would impair serviceability.

(3) Test. Check continuity of motor windings for open windings or windings shorted to motor frame. If any of these conditions are found or if rotor binds indicating defective bearings, replace motor

(4) Replace.

(a) Position replacement motor (9) on base (8) and secure with bolts (7), lockwashers (6) and nuts (5). Do not tighten nuts at this time.

(b) Connect ground wire (3) to motor capacitor mounting screw and to frame.

(c) Place fan housings (26, figure 3-5) over motor shaft on each side of motor and secure to frame with screws (9, 13, 24), washers (8, 12, 23), washers (7, 11, 22) and nuts (6, 10, 21).

(d) Match direction of rotation arrows on fans with arrows on fan housings and slide fans on to motor shaft. Position fans in the housings so that they are centered in the housings. Tighten setscrew (28) in fans to secure fans to motor shaft. Tighten motor mounting nuts (5, figure 3-6) to secure motor to frame and to base.

(e) Connect motor leads to terminal board. (See figure 3-2, electrical wiring diagram).

(f) Check direction of rotation of the fan motor. The fan motor must be wired for clockwise rotation. Direction is determined by looking at motor terminal end. Replacement motors are shipped wired for counterclockwise rotation. To reverse direction of rotation, reverse the red and black leads inside motor junction box. After the motor has been installed and wired, energize the unit to verify proper rotation. Direction of rotation arrows are marked on both the fans and the fan housings.

(g) Install rings (20, figure 3-5) and secure to housings (26) with washers (19) and screws (18).

(h) Refer to figure 3-3 and install front, rear and end panels.

### 3-10. EVAPORATOR COIL SECTION.

#### a. Covers, Panels and Frame.

(1) Removal. Remove the covers and panels by turning the fasteners one-quarter turn counterclockwise. (See figure 3-7).

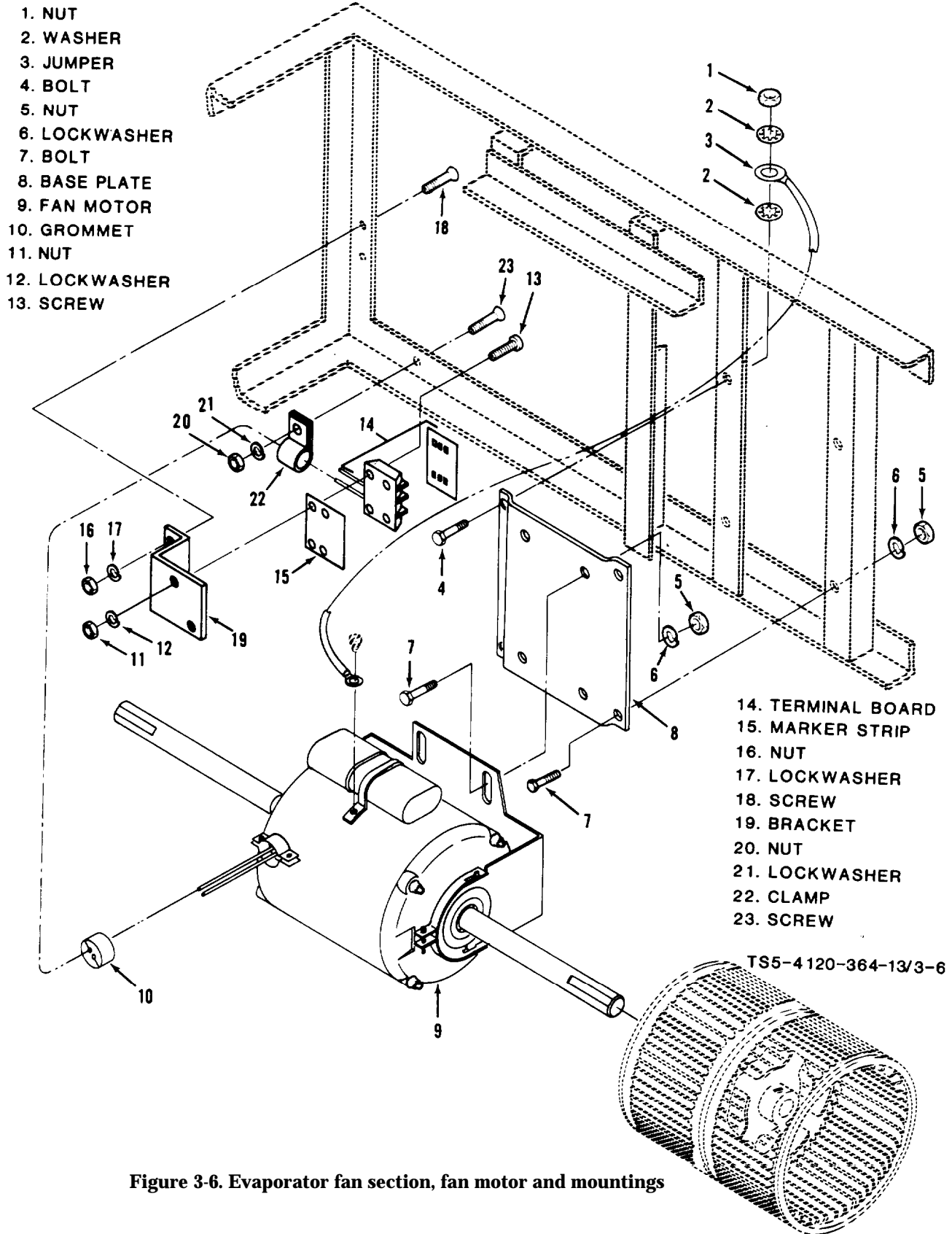
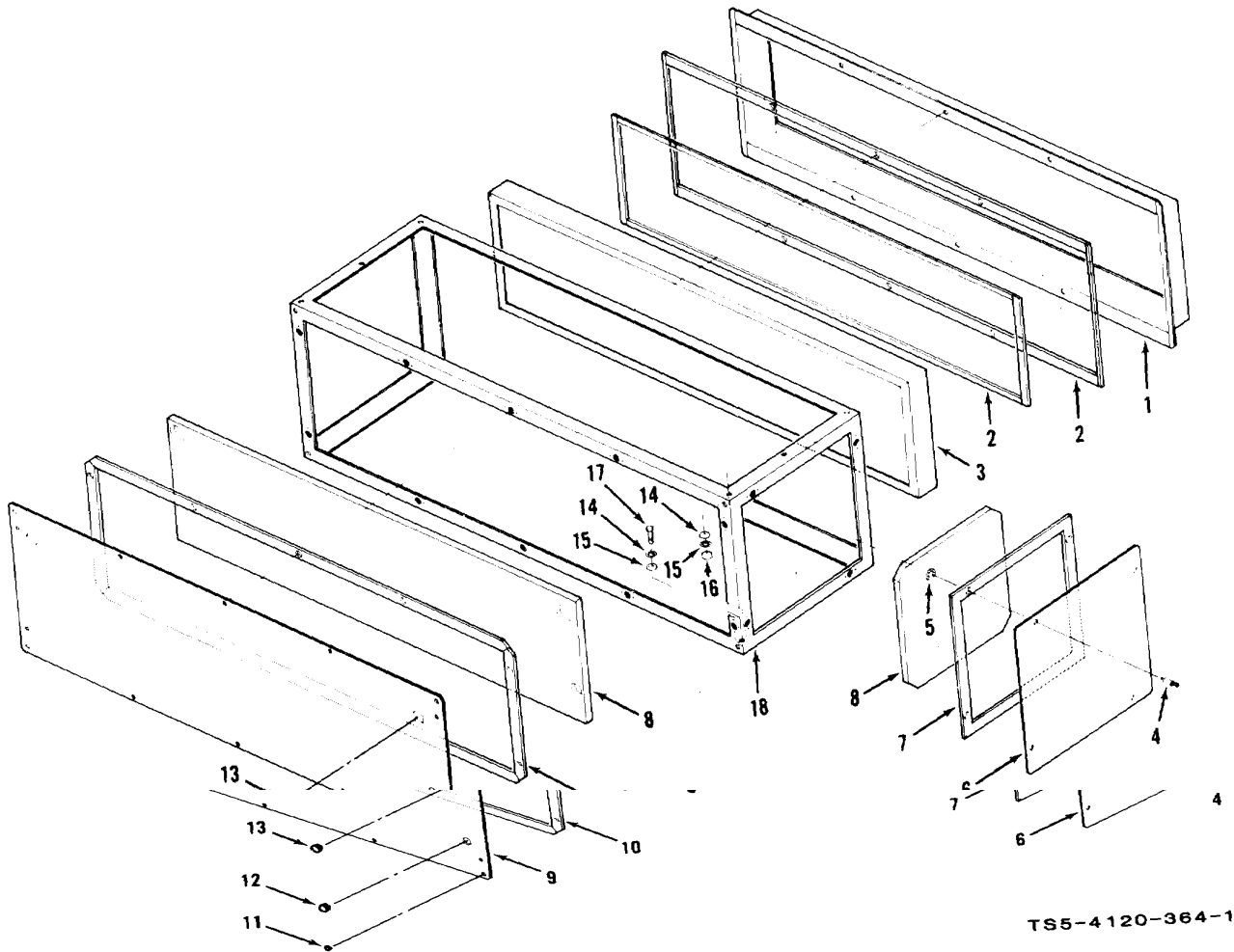

Figure 3-6. Evaporator fan section, fan motor and mountings

- 1. FILTER FRAME
- 2. GASKET
- 3. AIR FILTER
- 4. FASTENER
- 5. RETAINER
- 6. END COVER
- 7. GASKET
- 8. INSULATION
- 9. FRONT PANEL

- 10. GASKET
- 11. HOLE PLUG
- 12. HOLE PLUG
- 13. HOLE PLUG
- 14. WASHER
- 15. WASHER
- 16. NUT
- 17. BOLT



TS5-4120-364-13/3-7

Figure 3-7. Evaporate coil section, covers, panels and frame

(2) Cleaning. Clean all parts with a damp cloth and dry thoroughly.

(3) Inspection.

- (a) Inspect rowers and panels for dents or other damage,
- (b) Inspect fasteners and receptacles for security of attachment.
- (c) Inspect gaskets for wear or damage.
- (d) Inspect insulation for security of attachment and for condition.

(4) Repair.

- (a) Replace defective covers and panels.
- (b) Replace defective fasteners. (See figure 3-4).
- (c) Replace defective gaskets. New gaskets are installed by removing the strip from the gasket adhesive backing and pressing the gasket in place,
- (d) Glue loose or new insulation to the panels with adhesive.

(5) Installation. Refer to figure 3-7 and install covers and panels by turning fasteners one-quarter turn clockwise.

b. Evaporator Coil. Organizational maintenance of the evaporator coil is limited to cleaning. Clean outside of evaporator coil with water and dry with low pressure compressed air.

WARNING

When using compressed air for blowing and cleaning, air hose pressure must not exceed 30 psig, and individuals must wear eye protection equipment.

c. Air Filter. Refer to figure 3-8 and service or replace the air filter.

3-11. CONDENSER FAN SECTION.

a. Covers, Panels and Frame.

(1) Removal.

(a) Remove the end panels and rear cover panels by turning the fasteners (8, figure 3-9) one-quarter turn counterclockwise.

(b) Remove front panel by removing screws (22) and washers (23), then turn fasteners (8) one-quarter turn counterclockwise,

(2) Cleaning. Clean all parts with a damp cloth and dry thoroughly.

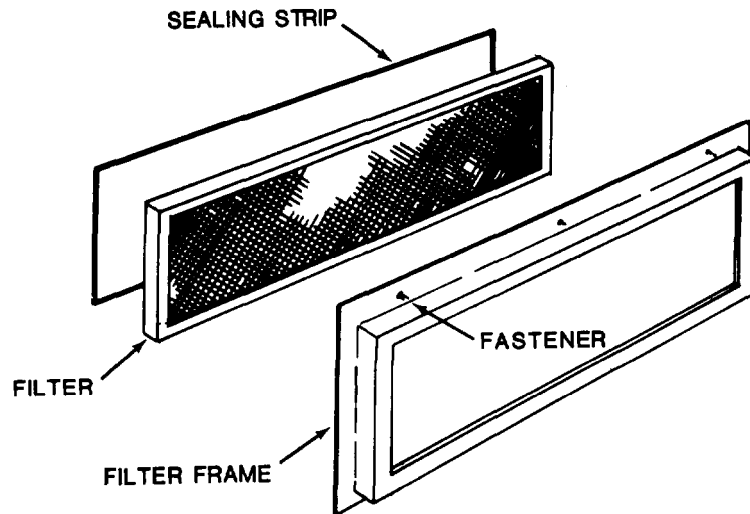

CLEANING AIR FILTER

1. REMOVE FILTER FRAME ASSEMBLY BY LOOSENING SIX FASTENERS.
2. TAKE OUT FILTER.
3. CLEAN FILTER WITH A STREAM OF WATER.
4. REPLACE FILTER IN FRAME.
5. REINSTALL FILTER FRAME ASSEMBLY.

TS5-4120-364-1313-8

**Figure 3-6. Air filter service**

(3) Inspection.

- (a) Inspect covers and panels for dents or other damage.
- (b) Inspect fasteners and receptacles for security of attachment.
- (c) Inspect gaskets for wear and damage.
- (d) Inspect insulation for security of attachment and for condition.

(4) Repair.

- (a) Replace defective covers and panels.
- (b) Replace defective fasteners. (See figure 3-4).
- (c) Replace defective gaskets. New gaskets are installed by removing the strip from the gasket adhesive backing and pressing the gasket in place.
- (d) Glue loose or new insulation to the panels with adhesive.

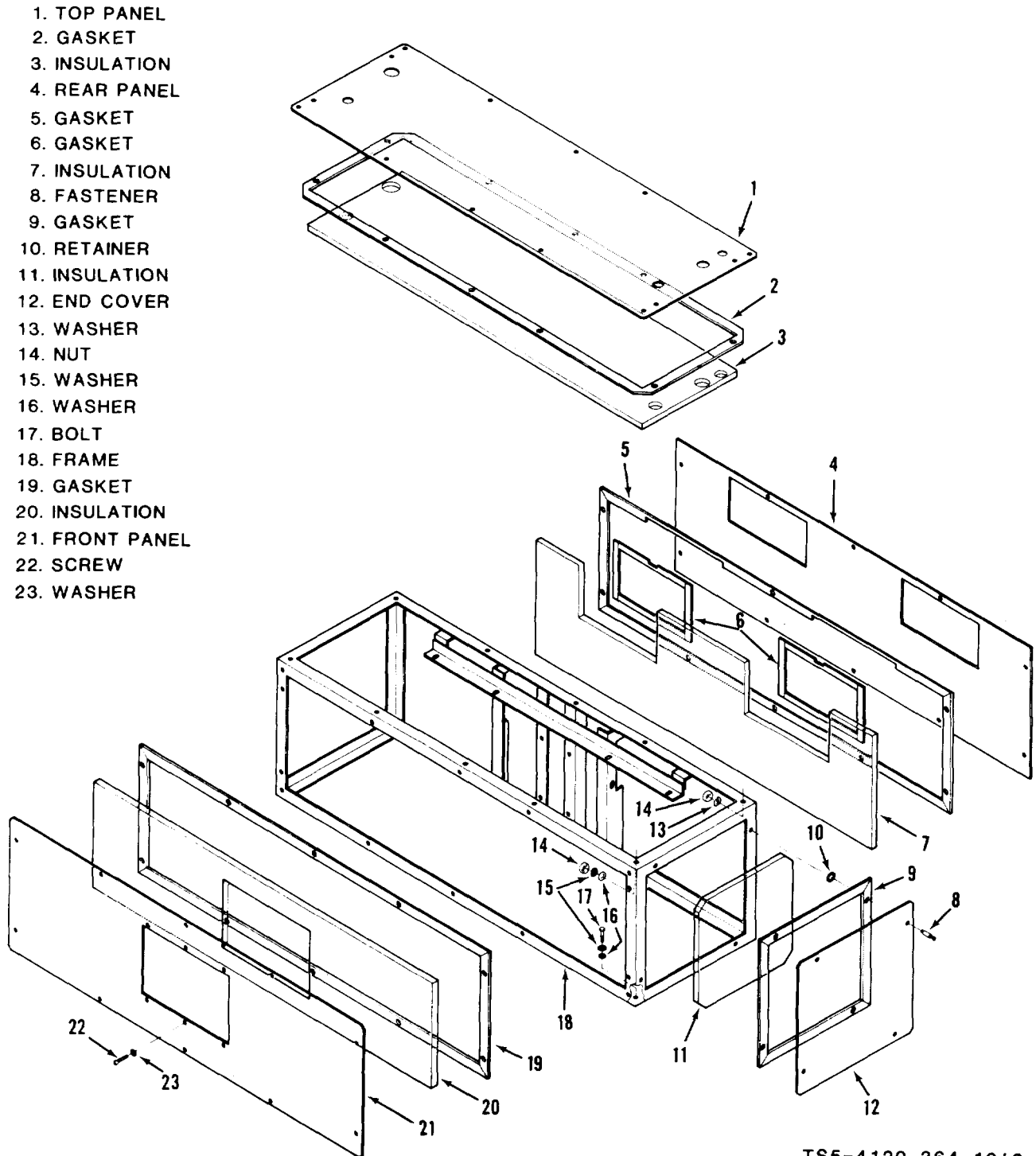

TS5-4120-364-13/3-9

Figure 3-9. Condenser fan section, covers, panels and frame

(5) Installation. Refer to figure 3-9 and install covers and panels by turning fasteners (8) one-quarter turn clockwise.

b. Control Panel and Controls.

**WARNING**

High voltage is on components in control box. Disconnect power leads to air conditioner before removing control panel.

(1) Removal.

(a) Turn main control switch to the OFF position and disconnect main power to air conditioner.

(b) Refer to figure 3-9 and remove six screws (22) and washers (23), then turn fasteners (8) one-quarter turn counterclockwise and remove panel (21).

(c) Loosen setscrew (23, figure 3-10 and remove knob (24) from temperature control (27).

(d) Turn six fasteners (22) one-quarter turn counterclockwise and remove control panel.

(e) Remove knob from selector switch (18), then remove screws (13) and washers (3) and remove selector switch.

(2) Installation.

(a) Secure selector switch (18) to back of control panel (16) with screws (13) and washers (3).

(b) Position control panel in place and secure with six fasteners (22) by turning fasteners one-quarter turn clockwise.

(c) Place knob (24) on shaft of temperature control (27) and secure with setscrew (23).

(d) Place knob on shaft of selector switch (18) and secure with screw.

(e) Refer to figure 3-9 and secure panel (21) to unit by turning fasteners (8) one-quarter turn clockwise. Install six screws (22) and washers (23).

c. Selector Switch.

(1) Removal.

(a) Refer to figure 3-10 and remove setscrew (23) and knob (24).

(b) Turn fasteners (22) one-quarter turn counterclockwise and remove control panel.



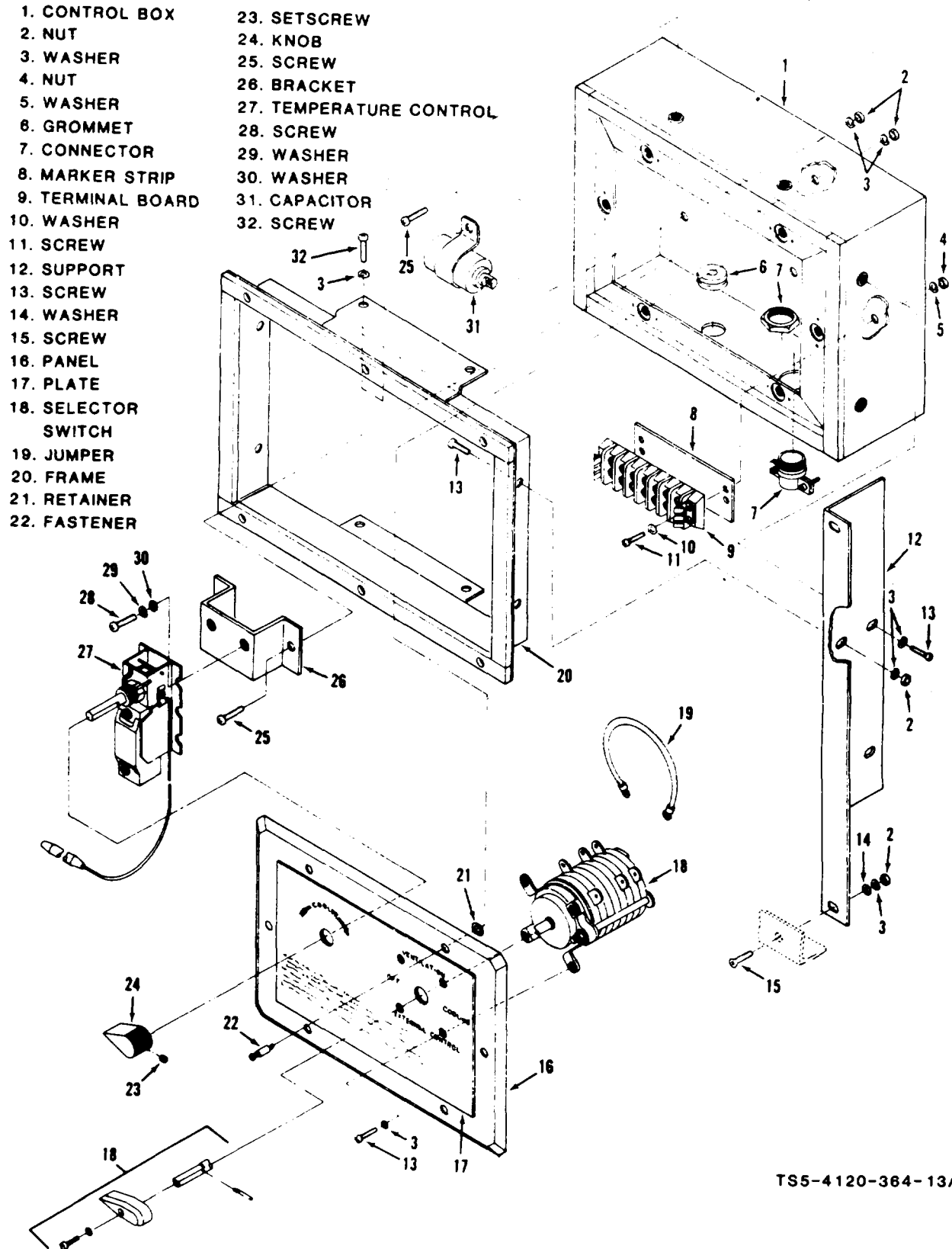

TS5-4120-364-13/3-10

Figure 3-10. Control panel and controls

(c) Tag and disconnect electrical leads from selector switch (18) and remove jumper (19).

(d) Remove screws (13), washers (3), then remove selector switch (18).

(2) Inspection.

(a) Check selector switch for freedom of rotation by rotating the knob 360 degrees.

(b) Check continuity through selector switch with a circuit tester. If selector switch is found to be defective, it must be replaced. Refer to Table 3-3.

**TABLE 3-3. SWITCH FUNCTIONS**

SWITCH POSITION	SWITCH FUNCTION	WAFER 1	WAFER 2	WAFER 3
1	OFF	4 AND 5		
2	VENT	4 5 AND 6		
3	COOL	5 AND 6	7 AND 8	
4	EXT CONTROL	4 AND 6		9 AND 10

(3) Installation.

(a) Position selector switch (18) on back of control panel (16) and secure with screw (13) and washers (3).

(b) Connect electrical leads and jumper to selector switch terminals.

(c) position control panel (16) in position and secure with fasteners (22) by turning fasteners one-quarter turn clockwise.

(d) Place control knob on selector switch shaft and secure with set-screw.

d. Temperature Control. Access to the temperature control is gained by removing knob (24, figure 3-10) from shaft of temperature control (27) and turning fasteners (22) one-quarter turn counterclockwise and removing control panel (16).

(1) Removal.

(a) Tag and disconnect electrical leads from temperature control (27).

(b) Loosen screws holding thermostat bulb to the evaporator coil frame bracket and slide bulb out. Push tubing and bulb through bulkhead.

(c) Remove screws (28), washers (29, 30) then remove temperature control (27) with tubing and bulb from the air conditioner.

(2) Inspection. Inspect the temperature control for damage which would impair serviceability.

(3) Repair. Repair of temperature control is accomplished by replacing a defective temperature control.

(4) Installation.

(a) Thread the sensing bulb and tubing of replacement temperature control through the bulkhead and secure sensing bulb to the evaporator coil frame bracket with clamp,

(b) Attach temperature control (27) to bracket (26) with screws (28) and washers (29, 30).



(c) Reconnect electrical leads.

(d) Install control panel (16) and secure with six fasteners (22). Turn fasteners one-quarter turn clockwise.

(e) Place knob (24) on shaft of temperature control (27) and secure with setscrew (23).

e. Fan Housings and Fans. The condenser fan assembly consists of a dual squirrel cage type fan and housings powered by a 1/3 HP, 120 volt, single phase, 50/60 Hz electric rotor. The rotor is equipped with permanently lubricated ball bearings and an overload protector which will reset itself automatically after cooling.

(1) Removal.

(a) Remove the end panels and rear cover by turning fasteners (8, figure 3-9) one-quarter turn counterclockwise.

(b) Remove front panel by first removing screws (22) and washers (23), then turn fasteners (8) one-quarter turn counterclockwise.

(c) Remove screws (13, figure 3-11), washers (14) and ring (15) from housings (25).

(d) Loosen setscrews (26) in fans (12) and remove fans from motor shaft.

(e) Remove nuts (6, 16), washers (7, 17, 18), screws (9, 20, 22), hose clamp (2), then remove housings (25) from frame.

(f) If required for replacement, remove nuts (16), washers (17, 18), screws (23) and grill (24).

(2) Inspection. Inspect fan, fan housings, and grills for evidence of damage which would impair serviceability.

(3) Repair. Repair of the fan housings and fans shall be by replacement of the defective component.

(4) Replace.

(a) If grills (24) are to be replaced, place grills into housings (25) and secure with screws (23), washers (17, 18) and nuts (16).

(b) Place housings in frame over motor shaft and secure with screws (9, 20, 22), washers (7, 17, 18) and nuts (6, 16).

(c) Slide fans (12) on to motor shaft and into housings (25). Make certain that fans clear housings and secure fans to motor shaft by tightening setscrews (26) in fan bushings.

(d) Attach rings (15) to housings (25) with screws (13), washers (14).

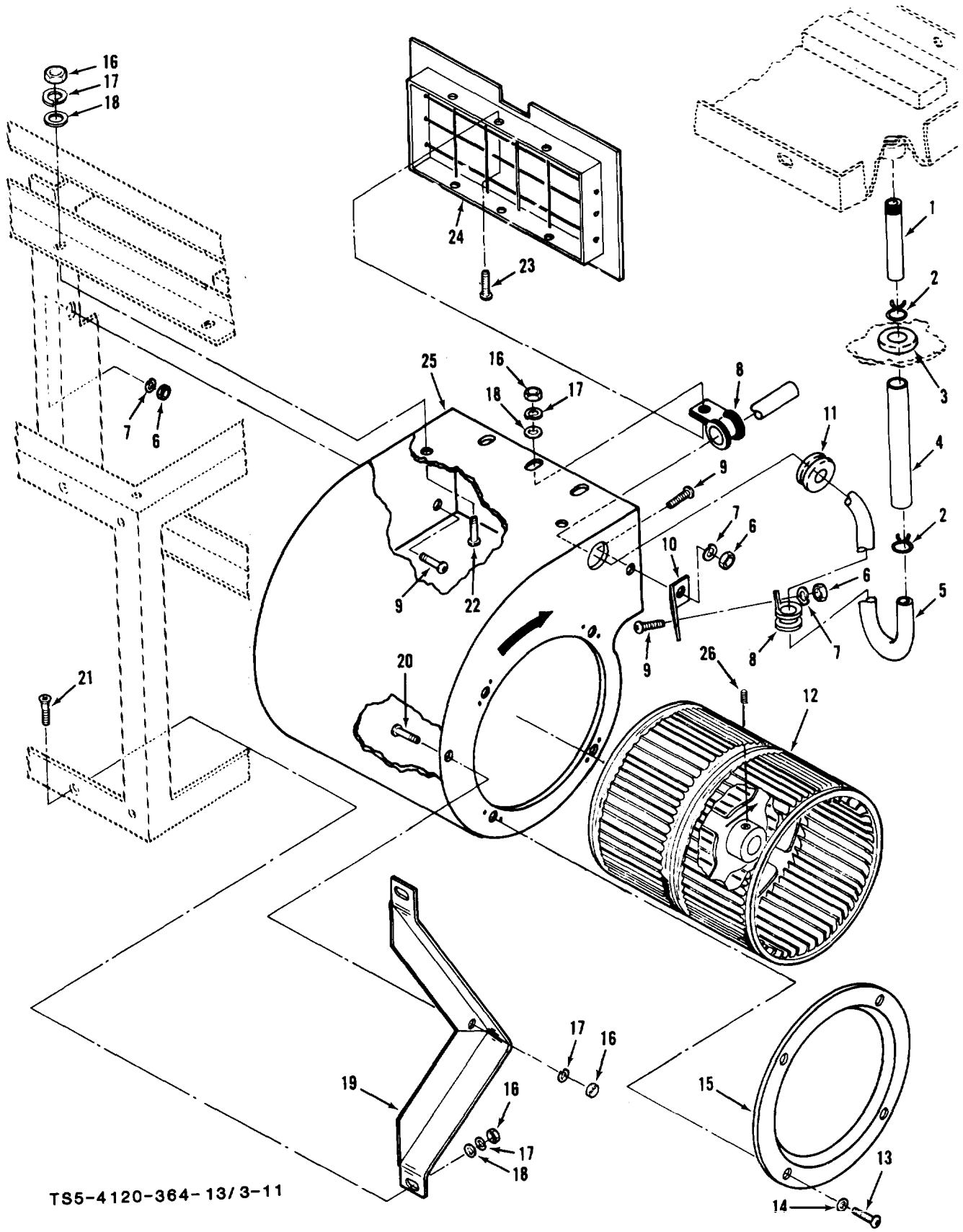

TS5-4120-364-13/3-11

Figure 3-11. Condenser fan section, fan housing and fans

## KEY TO FIGURE 3-11

1. TUBE	10. BRACKET	19. SUPFORT
2. CLAMP	11. GROMMET	20. SCREW
3. GROMMET	12. FAN	21. SCREW
4. HOSE	13. SCREW	22. SCREW
5. PIPE	14. WASHER	23. SCREW
6. NUT	15. RING	24. GRILL
7. LCCKWASHER	16. NUT	25. HOUSING
8. CLAMP	17. LOCKWASHER	26. SETSCREW
9. SCREW	18. WASHER	

(e) Connect pipe (5) to hose (4) with clamp (2).

(f) Refer to figure 3-9 and attach front, rear and end panels by turning fasteners (8) one-quarter turn clockwise and installing screws (22) and washers (23).

f. Fan Motor.

**WARNING**

Disconnect the power leads to the air conditioner before removing the fan motor.

(1) Removal.

(a) Remove the end panels and rear cover by turning fasteners (8, figure 3-9) one-quarter turn counterclockwise.

(b) Remove front panel by first removing screws (22) and washers (23), then turn fasteners (8) one-quarter turn counterclockwise.

(c) Disconnect pipe (5, figure 3-11) from hose (4) by releasing clamp (2). Do this on both housings (25).

(d) Remove screws (13), washers (14) and ring (15) from housings (25). Remove this ring from both housings (25) on each side of motor.

(e) Loosen setscrew (26) in both fans (12) and remove fans from motor shaft. Remove fans from both sides of rotor.

(f) Rcmove nuts (7, 16), washers (8, 17, 18), screws (9, 20, 22), then remove housings (25) from frame. Remove both housings from frame.

(g) Disconnect and tag motor leads from terminal board (11, figure 3-12) and remove ground wire (3) from frame and motor.

(h) Remove nut (5), lockwasher (6) and bolt (7) and remove fan motor (9) from base (8) and frame.

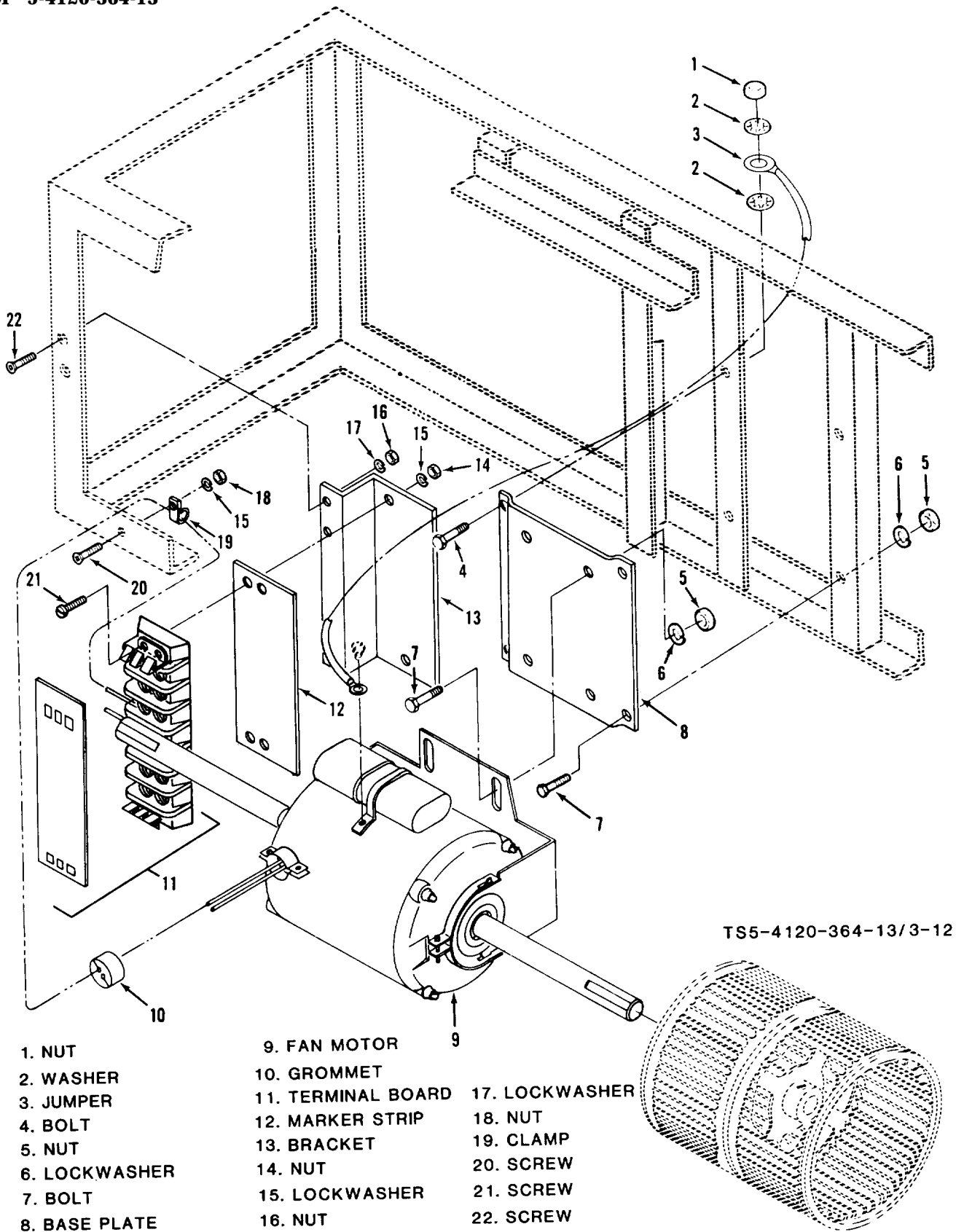

Figure 3-12. Condenser fan section, fan motor and mountings



(2) Inspect. Inspect fan motor for loose wire connections, frayed or burned wires or other evidence of damage which would impair serviceability.

(3) Test. Check continuity of rotor windings for open windings or windings shorted to motor frame. If any of these conditions are found, or if motor binds indicating defective bearings, replace motor.

(4) Replace.

(a) Position replacement fan motor (9) on base (8) and secure with knits (7), lockwashers (6) and nuts (5). Do not tighten nuts (5) at this time.

(b) Connect ground wire (3) to motor capacitor mounting screw and to frame.

(c) Place fan housings (25, figure 3-11) over rotor shaft on each side of rotor and secure with screws (9, 20, 22), washers (7, 17, 18) and nuts (6, 16).

(d) Match direction of rotation arrows on fans with arrows on fan housings and slide fans on to motor shaft. Position fans in the housings so that they are centered in the housings. Tighten setscrews (26) in fans to secure fans to motor shaft. Tighten motor mounting nuts (5, figure 3-12) to secure rotor to frame and base.

(e) Connect motor leads to terminal board. Refer to electrical wiring diagram figure 3-2.

(f) Check direction of rotation of the fan motor. The condenser fan motor must be wired for counterclockwise rotation. Direction is determined by looking at motor terminal end. Replacement motors are shipped wired for clockwise rotation. To reverse direction of rotation, reverse the red and black leads inside motor junction box. After the motor has been installed and wired, energize unit to verify proper rotation. Direction of rotation arrows are marked on both the fans and the fan housings.

(g) Attach rings (15, figure 3-11) to housings (25) with screws (13) and washers (14).

(h) Connect pipe (5) to hose (4) with clamp (2).

(i) Refer to figure 3-9 and attach front, rear and end panels by turning fasteners (8) one-quarter turn clockwise and installing screws (22) and washers (23).

g. Refrigerant Sight Glass. Organizational maintenance of the sight glass is limited to checking the refrigerant through the sight glass. The refrigerant should appear as a clear blue liquid. (Check color code on sight glass cap). If bubbling, fogging, or a pink color appears, report the condition to direct support maintenance.

### 3-12. CONDENSER COIL SECTION.

#### a. Covers, Panels and Frame.

(1) Removal. Remove the covers and panels by turning the fasteners (9, figure 3-13) one-quarter turn counterclockwise.

- |               |                |
|---------------|----------------|
| 1. SUPPORT    | 9. FASTENER    |
| 2. FRAME      | 10. PANEL      |
| 3. WASHER     | 11. GASKET     |
| 4. NUT        | 12. INSULATION |
| 5. INSULATION | 13. WASHER     |
| 6. GASKET     | 14. WASHER     |
| 7. RETAINER   | 15. BOLT       |
| 8. END COVER  | 16. SCREW      |

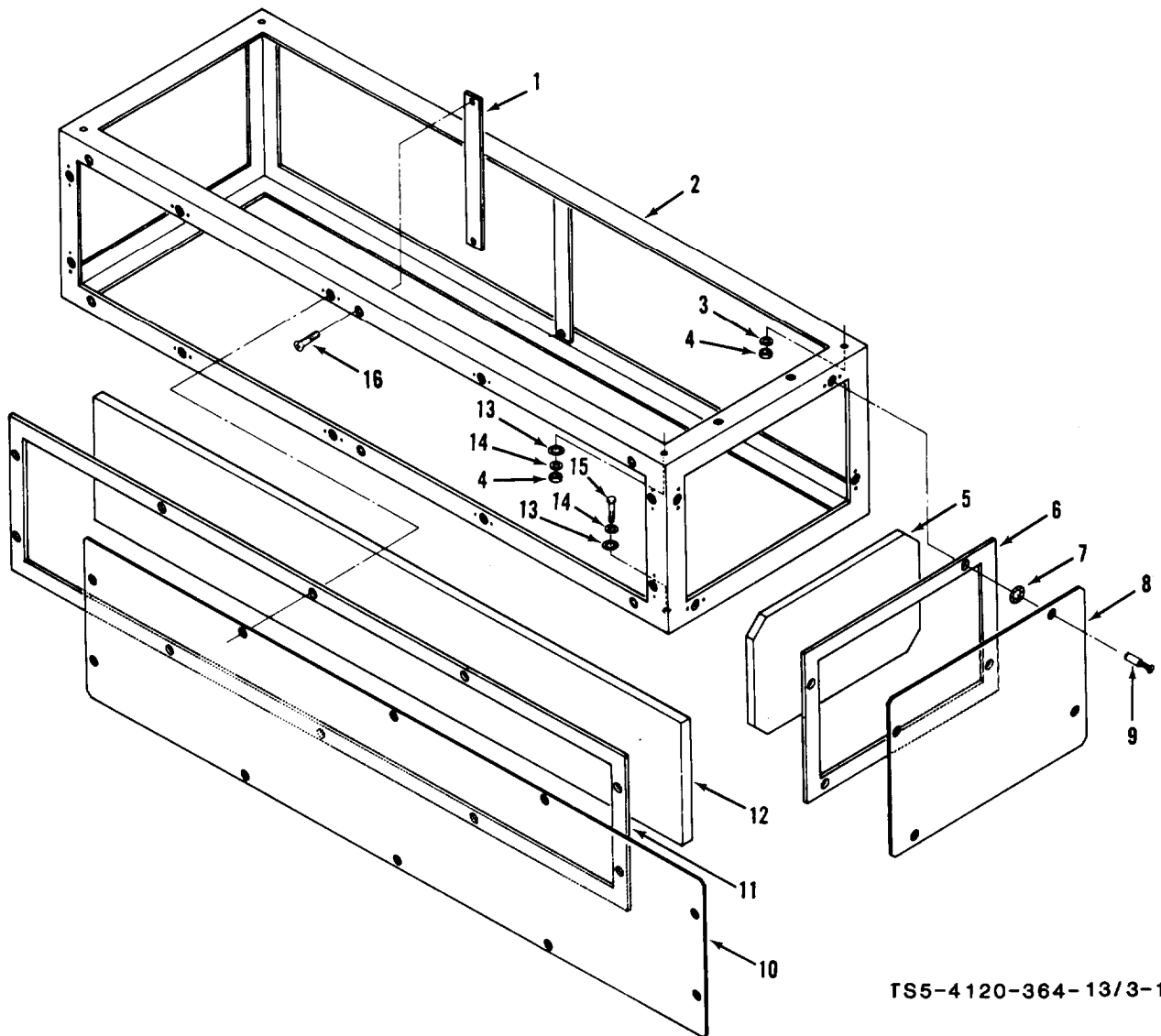

TS5-4120-364-13/3-13

Figure 3-13. Condenser coil section, covers, panels and frame

(2) Cleaning. Clean all parts with a damp cloth and dry thoroughly.

(3) Inspection.

(a) Inspect covers and panels for dents or other damage.

(b) Inspect fasteners and receptacles for security of attachment.

(c) Inspect gaskets for wear.

(d) Inspect insulation for security of attachment and for condition.

(4) Repair.

(a) Replace defective covers and panels.

(b) Replace defective fasteners. (See figure 3-4).

(c) Replace defective gaskets. New gaskets are installed by removing the strip from the gasket adhesive backing and pressing the gasket in place.

(d) Glue loose or new insulation to the panels with adhesive.

(5) Installation. Refer to figure 3-13 and install covers and panels by turning fasteners (9) one-quarter turn clockwise.

b. Condenser Coil and Tubes.

#### WARNING

When using repressed air for blowing and cleaning, air hose pressure must not exceed 30 psig, and individuals must wear eye protection equipment.

Organizational maintenance of the condenser coil and tubes is limited to inspection for damage and cleaning the coil. Clean outside area of coil with water and dry with low pressure repressed air.

3-13. COMPRESSOR SECTION.

a. Covers, Panels and Frame.

(1) Removal. Remove the covers and panels by turning the fasteners (14, figure 3-14) one-quarter turn counterclockwise.

(2) Cleaning. Clean all parts with a damp cloth and dry thoroughly.

(3) Inspection.

(a) Inspect covers and panels for dents and other damage.

(b) Inspect fasteners and receptacles for security of attachment.

- |                |                |
|----------------|----------------|
| 1. GROMMET     | 14. FASTENER   |
| 2. PANEL       | 15. HOLE PLUG  |
| 3. HOLE PLUG   | 16. HOLE PLUG  |
| 4. HOLE PLUG   | 17. PANEL      |
| 5. INSULATION  | 18. GASKET     |
| 6. GASKET      | 19. WASHER     |
| 7. FRAME       | 20. WASHER     |
| 8. NUT         | 21. PANEL      |
| 9. WASHER      | 22. GASKET     |
| 10. INSULATION | 23. GASKET     |
| 11. GASKET     | 24. INSULATION |
| 12. RETAINER   | 25. END COVER  |
| 13. END COVER  |                |

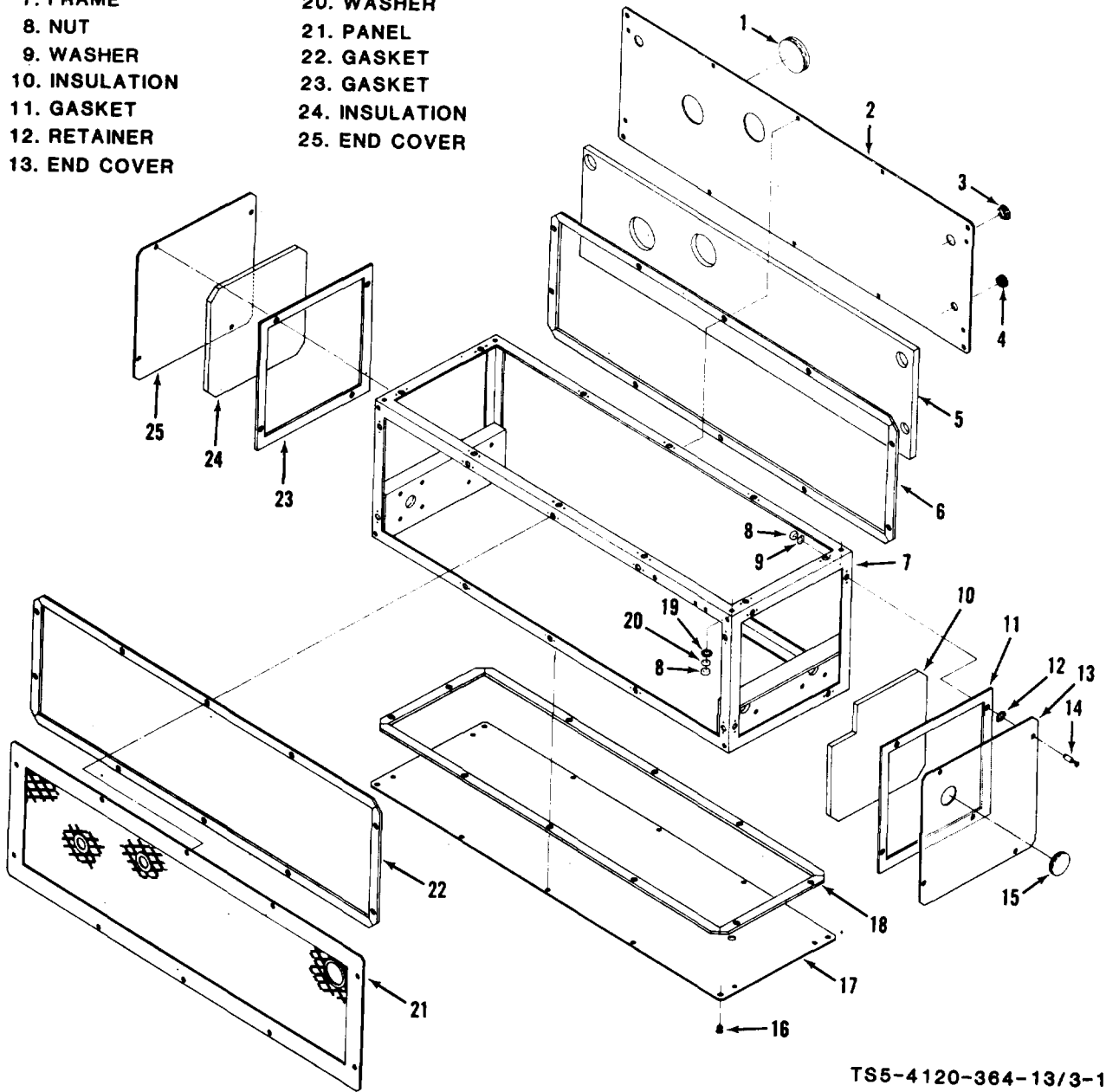

TS5-4120-364-13/3-14

Figure 3-14. Compressor section, covers, panels and frame

(c) Inspect gaskets for wear.

(d) Inspect insulation for security of attachment and for condition.

(4) Repair.

(a) Replace defective covers and panels.

(b) Replace defective fasteners. (See figure 3-4).

(c) Replace defective gaskets. New gaskets are installed by removing the strip from the gasket adhesive backing and pressing gasket in place.

(d) Glue loose or new insulation to the panels with adhesive.

(5) Installation. Refer to figure 3-12 and install covers and panels by turning fasteners (14) one-quarter turn clockwise.

b. Motor Compressor Assembly. Organizational maintenance on the motor compressor assembly is limited to general cleaning and inspection of the oil sight glass. Oil should be visible in the compressor oil sight glass at all times. If oil is not visible in the sight glass, notify Direct Support Maintenance.

c. High Pressure Cutout Switch.

(1) Inspect the high pressure cutout switch for leaks, kinks in tubing, and for frayed, loose or burned wires, and for any evidence of damage which would impair serviceability.

(2) If any defect or damage is found, notify Direct Support Maintenance.

d. Electrical Contactor.

(1) Removal. The electrical contactor is located in a box in the compressor section and is accessible after removing the grill panel from the compressor section. Remove electrical contactor as follows:

(a) Disconnect the power connector on the back of the unit, then remove the grill panel from the compressor section.

(b) Remove cover panel from box containing the electrical contactor.

(c) Tag and disconnect electrical leads from electrical contactor.

(d) Refer to figure 3-15 and remove three mounting screws then remove electrical contactor from box.

(2) Inspect. Inspect electrical contactor for loose or missing terminals, evidence of burned wires or other damage which would impair serviceability.

(3) Repair.

(a) Tighten loose or replace missing terminals or burned jumper wires.

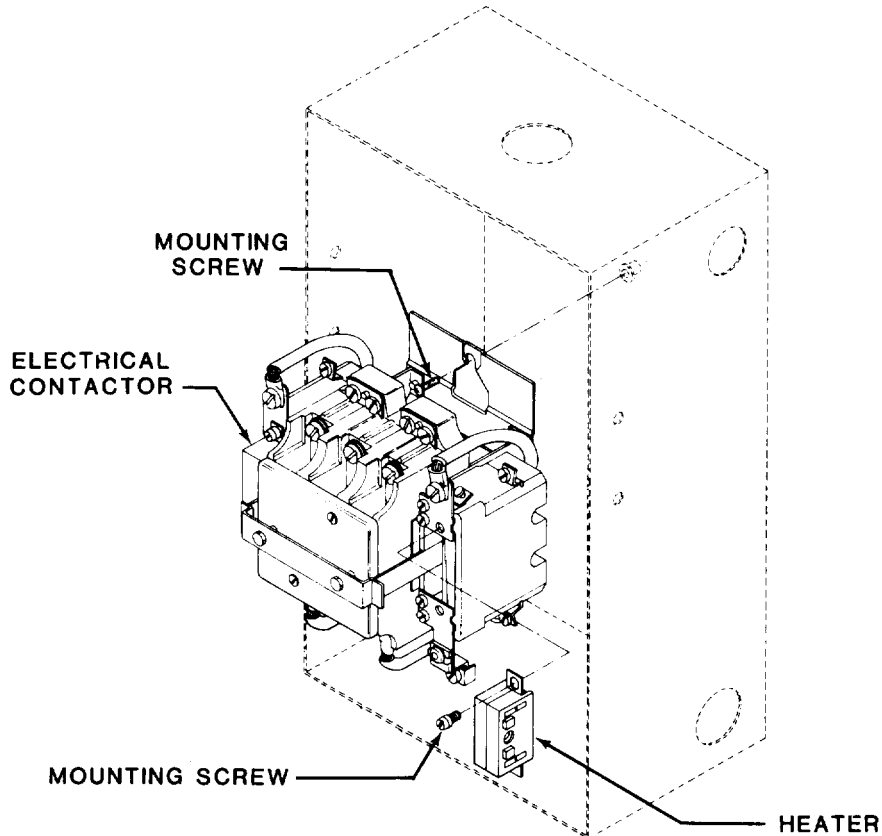

Figure 3-15. Electrical contactor TS5-4120-364-13/3-15

(b) Replace defective heaters by removing heater mounting screws on each side of contactor, then remove heaters.

(c) Install new or replace heaters and secure with heater mounting screws.

**NOTE**

The contactor contains two heaters. Both heaters must be of the same electrical characteristics. Make sure that the heaters used are correct for the primary power source being used, either 120 or 208 volts.

(4) Replace.

(a) Position the electrical contactor in the box and secure with three mounting screws.

(b) Refer to figure 3-2 and reconnect electrical leads. Be certain to connect the electrical leads correctly for the primary power source being used, either 120 or 208 volts.

## CHAPTER 4

## DIRECT SUPPORT MAINTENANCE

## Section I. Repair Parts, Special Tools, TMDE, and Support Equipment

## 4-1. REPAIR PARTS.

Repair parts are listed and illustrated in the repair parts and special tools list TM 5-4120-364-23P covering direct support maintenance of this equipment.

## 4-2. SPECIAL TOOLS, TMDE, AND SUPPORT EQUIPMENT

Tool Kit, Service, Refrigeration Unit, LINW5362 is the only special tool required to perform direct support maintenance on the air conditioner.

## Section II. Troubleshooting

## 4-3. TROUBLESHOOTING TABLE.

a. The troubleshooting table (table 4-1) lists the common malfunctions which you may find during the operation or maintenance of the air conditioner or its components. You should perform the test/inspections and corrective actions in the order listed.

b. This manual cannot list all malfunctions that may occur, however, all tests or inspections and corrective actions are listed for most common malfunctions. If a malfunction is not listed or is not corrected by listed corrective actions, notify your supervisor.

## Section III. Maintenance Procedures

## 4-4. REFRIGERANT SYSTEM.

Nearly all operations for the correction of malfunctions found in troubleshooting, or maintenance activities of direct support require that the refrigeration system be opened to sane extent. Refer to the following paragraphs: 4-5 through 4-10 for steps to be taken before performing maintenance. See figure 4-1 for refrigeration fluid diagram.

## 4-5. PRESSURE GAGES, INSTALLATION AND REMOVAL.

a. Refer to figure 4-2 and backseat the suction service valve and remove cap from port.

b. Install and tighten a compound pressure gage (suction pressure), (30 inches vacuum, 100 pounds pressure).

c. Turn valve stem one turn clockwise so gage will register,

d. Backseat discharge service valve and remove sensing element line of high pressure switch from service valve port by removing flare nut and tube.

e. Install high pressure gage (0 to 300 pounds pressure).

**Table 4-1. Troubleshooting**

---

MALFUNCTION

TEST OR INSPECTION

CORRECTIVE ACTION

---

1. INSUFFICIENT COOLING

Step 1. Insufficient refrigerant in system.

Add refrigerant (para. 4-8).

Step 2. Defective expansion valve,

Replace expansion valve (figure 4-4).

Step 3. Discharge service, discharge shutoff, receiver outlet, suction line shutoff, or suction line service valve(s) closed.

Open valve(s) (figure 4-3).

Step 4. Air in refrigerant system.

Evacuate refrigerant system (para 4-9) and charge with refrigerant (para 4-10).

Step 5. Clogged filter drier.

Replace filter drier ( para. 4-13).

Step 6. Restriction in liquid line.

Open system and remove restriction.

Step 7. Refrigerant overcharge,

Purge the refrigerant system until proper charge for system is attained. (13 pounds 8 ounces of Type 12 refrigerant).

2. AIR CONDITIONER NOISY DURING OPERATION.

Step 1. Compressor oil level low.

Add oil to compressor until level shows up to one-half of the oil sight glass on the rotor compressor.

Step 2. Compressor sluggish due to overcharge.

Purge refrigerant system of refrigerant until proper charge is attained. (13 pounds 8 ounces of Type 12 refrigerant).



**Table 4-1. Troubleshooting (continued)**

## MALFUNCTION

## TEST OR INSPECTION

## CORRECTIVE ACTION

## 3. COMPRESSOR SHORT CYCLES.

Step 1. Excessive refrigerant in system.

Purge refrigerant system of refrigerant until proper charge is attained. (13 pounds 8 ounces of Type 12 refrigerant).

Step 2. Air or non-condensable gas in refrigerant system.

Purge the refrigerant system and recharge with refrigerant (para 4-10).

## 4. AIR CONDITIONER OPERATES CONTINUOUSLY.

Step 1. Insufficient refrigerant in system.

Add refrigerant (para 4-8).

## 5. AIR CONDITIONER STOPS DUE TO HIGH PRESSURE SWITCH TRIPPING.

Step 1. Refrigerant overcharge.

Purge refrigerant system of refrigerant until proper charge is attained. (13 pounds 8 ounces of Type 12 refrigerant).

Step 2. Condenser air flow restricted.

Clean condenser coil or remove restriction.

## 6. MOTOR COMPRESSOR KNOCKS OR DEVELOPS SUDDEN NOISE.

Step 1. Defective expansion valve.

Adjust or replace expansion valve (para 4-11 and figure 44).

Step 2. Internal failure (connecting rod, piston, bearing, etc) in compressor

Remove and replace rotor compressor (para 4-16 and figures 4-10, 4-11).

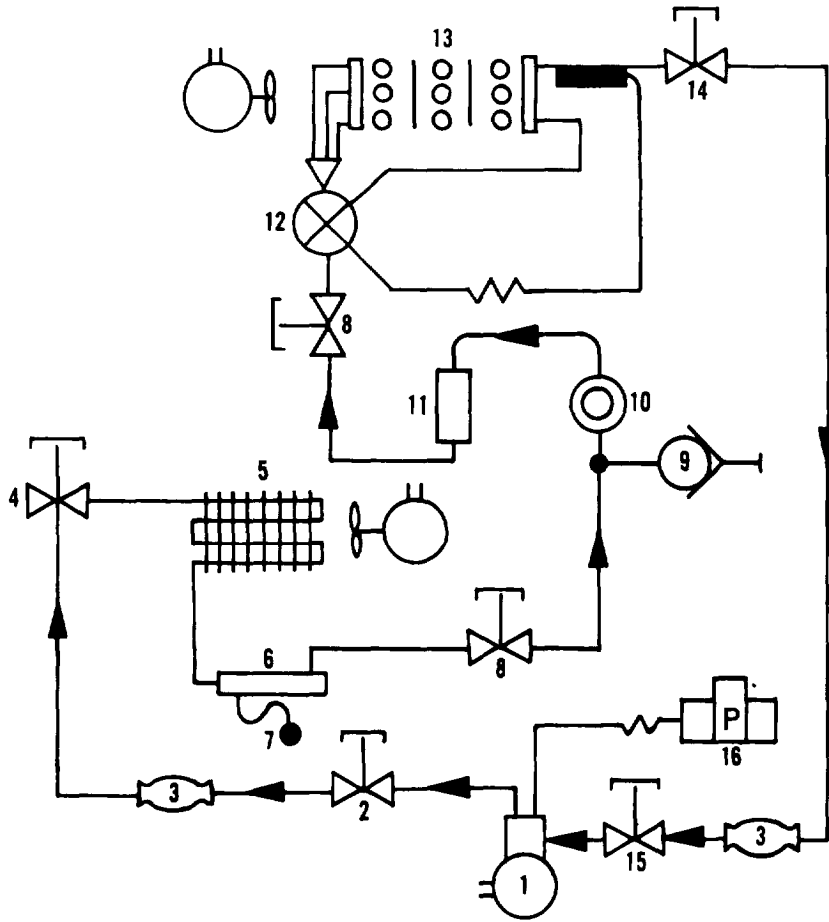

- |                              |                      |
|------------------------------|----------------------|
| 1. MOTOR COMPRESSOR ASSEMBLY | 9. CHARGING VALVE    |
| 2. COMPRESSOR VALVE          | 10. SIGHT GLASS      |
| 3. METAL HOSE ASSEMBLY       | 11. FILTER DRIER     |
| 4. SHUTOFF VALVE             | 12. EXPANSION VALVE  |
| 5. CONDENSER COIL            | 13. EVAPORATOR COIL  |
| 6. RECEIVER (PART OF 5)      | 14. SHUTOFF VALVE    |
| 7. FUSIBLE PLUG              | 15. COMPRESSOR VALVE |
| 8. SHUTOFF VALVE             | 16. PRESSURE SWITCH  |

Figure 4-1. Refrigeration flow diagram

TS 5-4120 -364-13/4-1

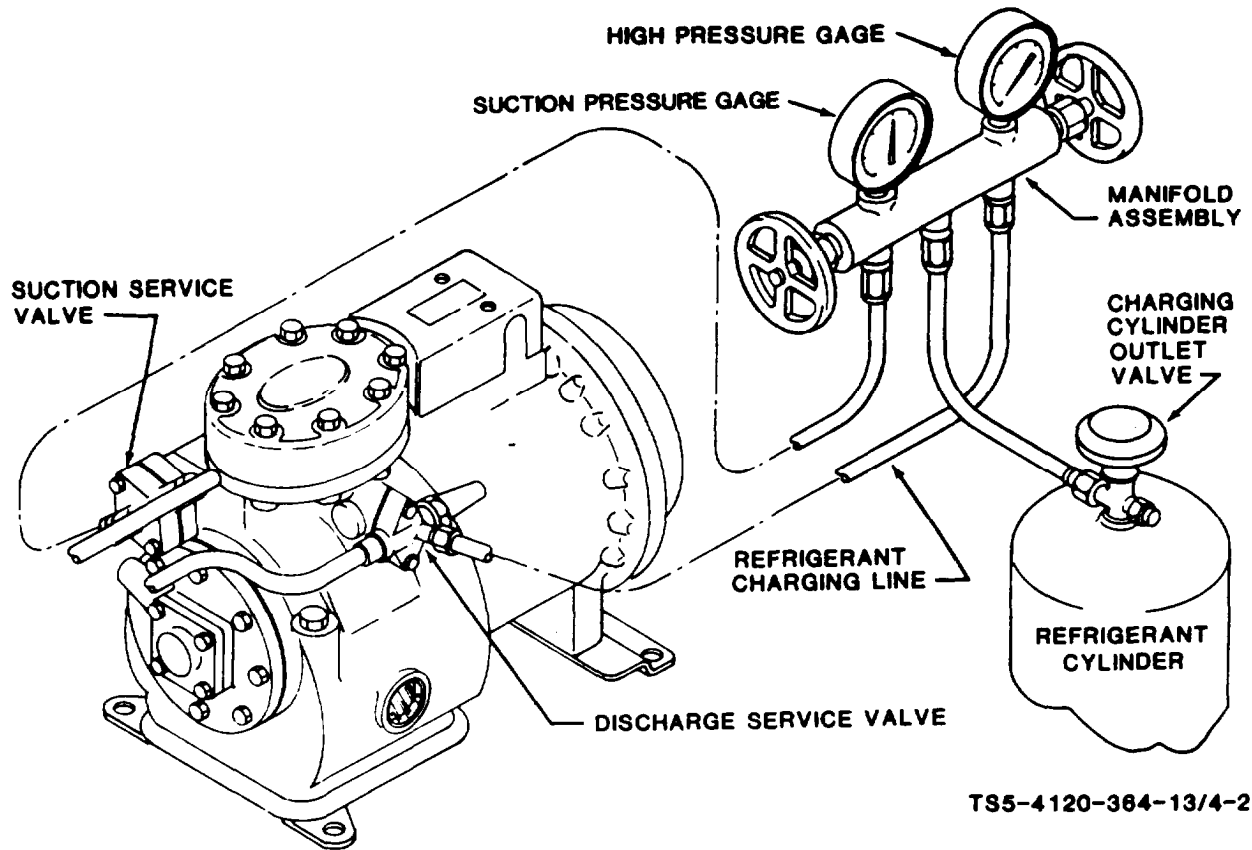

Figure 4-2. Installation of pressure gages

- f. Turn valve stem one turn clockwise so gage will register.
- g. After testing is completed, or gages are no longer required for other purposes, backseat the suction and discharge service valves on the compressor. Remove the gage lines and replace cap and high pressure switch sensing element tube. Open suction and discharge service valves on compressor fully to return unit to service.

#### 4-6. PUMPING DOWN REFRIGERANT SYSTEM.

a. General. Before the refrigerant system can be opened, it is necessary to liquify as much refrigerant as possible and contain it in the receiver portion of the condenser coil. This procedure of transferring refrigerant out of the system to the receiver is called pumping down.

b. To pump down the system, proceed as follows:

- (1) Make sure that all valves are open with the exception of the charging

valve. (Refer to figure 4-3).

(2) Close the condenser shutoff valve (outlet) by turning valve stem fully clockwise.

(3) Install a suction pressure gage on the compressor suction service valve as shown in figure 4-2.

(4) Operate the unit until suction pressure gage registers 5 to 10 inches ( 12.75 to 25.5cm) of mercury vacuum.

(5) Shut off machine and observe pressure gage for a few minutes. If pressure rebuilds, repeat step (4) until pressure does not rebuild appreciably.

(6) Crack condenser shutoff valve (outlet) until 3 to 4 psig is indicated on the suction pressure gage.

(7) Close condenser shutoff valve (inlet) by turning valve stem clockwise as far as it will go.

(8) Remove suction pressure gage from compressor suction service valve.

#### 4-7. OPENING THE SYSTEM.

Before opening the refrigerant system, the pressure in the system should be known. If the system is under high pressure, excessive loss of refrigerant will occur. If opened under vacuum, air is drawn into the system which will cause operating difficulties. If the pressure gage indicates a vacuum after pumping down, open the receiver outlet valve slightly to build 3 to 4 pounds pressure in the system.

#### 4-7.1 DISCHARGING THE REFRIGERANT SYSTEM.

##### **NOTE**

In accordance with Environmental Protection Agency regulations, refrigerants cannot be discharged into the atmosphere. A refrigerant recovery & recycling unit must be used whenever discharging the refrigerant system.

Operation of the recovery/recycling unit must be by  
AUTHORIZED PERSONNEL ONLY

- a. Remove service valve caps.
- b. Connect charging manifold service hoses to unit service valves.
- c. Connect and operate a recovery/recycling unit in accordance with the manufacturer's instructions.

## 4-8. ADDING REFRIGERANT.

a. General. Bubbles or a milky or frothy appearance of the refrigerant passing the sight glass in normal operation is indication that the system needs additional refrigerant. The normal refrigerant charge in the unit when shipped is 13 pounds 8 ounces of refrigerant R-12. Test for leaks with available leak detector, repair leak and add refrigerant.

b. Adding Refrigerant. When adding refrigerant to the system, connect the service gage hookup shown in figure 4-2 and proceed as follows:

(1) Turn stem of suction service valve counterclockwise as far as possible.

(2) Connect a line from the R-12 charging cylinder to connection on compressor suction valve. Leave connection loose at the compressor valve and open charging cylinder outlet valve long enough to purge all air from the charging line through the loose connection. Tighten charging line connection at compressor suction valve when gas can be heard escaping from the loose connection.

(3) Turn suction service valve clockwise 3 or 4 turns.

(4) Open charging cylinder outlet valve 1 or 2 turns.



(5) Turn selector switch on air conditioner control panel to COOLING.

(6) Observe sight glass while the unit is operating. When frothiness disappears, turn suction service valve counterclockwise as far as it will go. Watch sight glass for approximately 10 minutes to be sure bubbles do not reappear.

(7) Close outlet valve of charging cylinder and backseat the suction service valve.

(8) Disconnect charging line from suction valve and replace cap.

(9) Return unit to normal operation.

#### 4-9. EVACUATING THE REFRIGERANT SYSTEM.

a. General. When the refrigerant system is opened for servicing, there is a possibility of air entering the system. Before closing the system, that portion of the system which has been opened must be purged of air.

b. Evacuating the low side. When the unit is pumped down to service the low side and there is refrigerant in the receiver, proceed as follows:

(1) Front seat the discharge service valve if it is open. (See figure 4-3). Remove plug from the service port of the suction service valve on the compressor. (See figure 4-2).

(2) Open the receiver outlet valve slightly and allow gas to escape through the suction valve port for a few seconds. Replace the plug on the service valve port.

(3) Open the receiver outlet valve slightly and build pressure to 30 pounds.

(4) Open all valves fully and place the unit in operation to inspect the refrigerant charge.

c. Evacuating the high side. When the unit has been pumped down to service the high side and there is refrigerant in the receiver, proceed as follows:

(1) Open the discharge service valve (figure 4-3), about halfway so the port is open to the condenser. Remove plug from service valve port.

(2) Open condenser shutoff valve slightly and allow gas to escape for a few seconds. Replace plug on service valve port.

(3) Open receiver outlet valve slightly and build pressure to 30 pounds. Test for leaks using available leak detector.

(4) Open all refrigerant valves (turn discharge service valve one-half turn clockwise) and place unit in operation to inspect refrigerant charge.

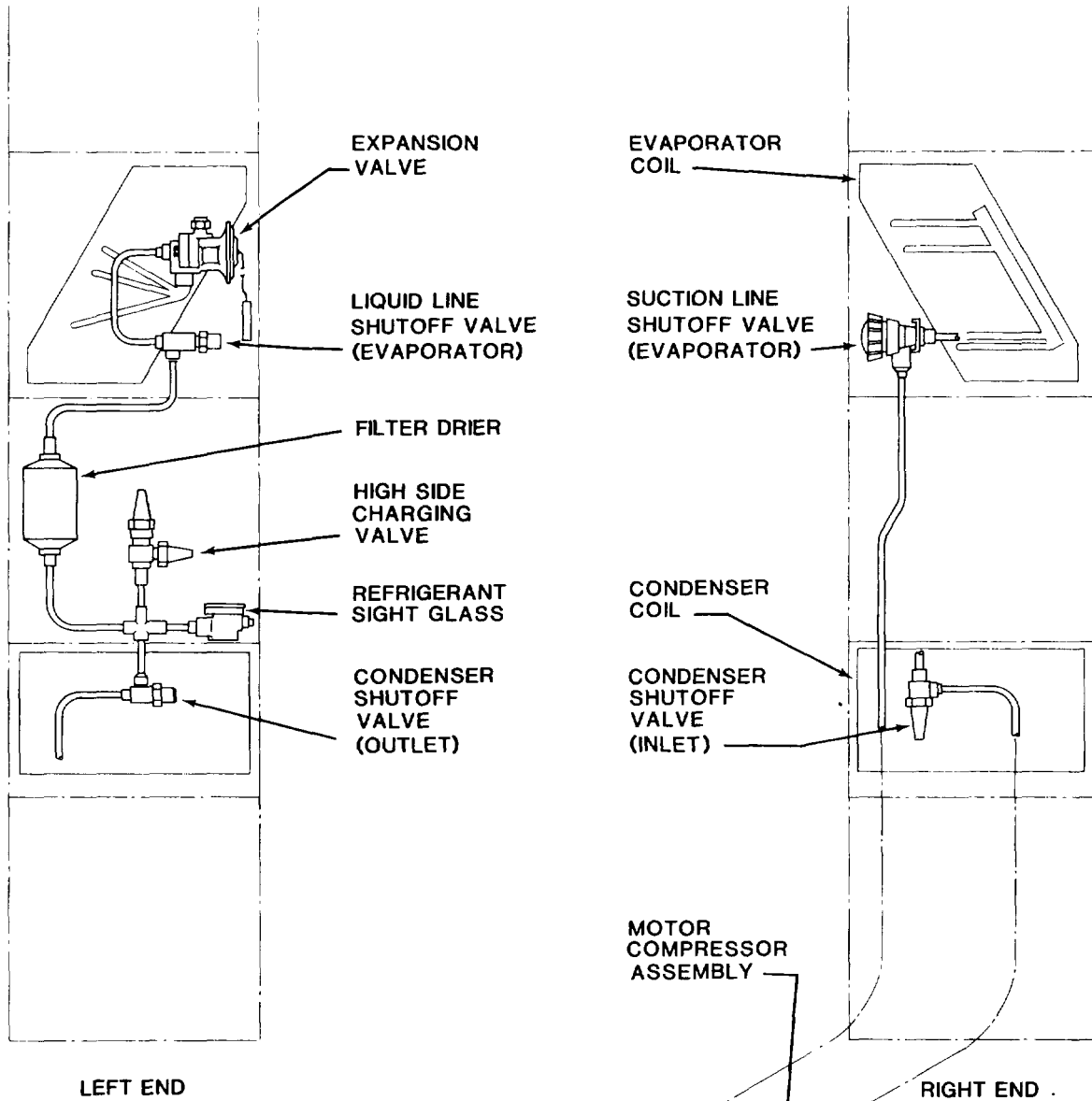

NOTE: RIGHT AND LEFT END IS DETERMINED AS YOU FACE THE CONTROL PANEL.

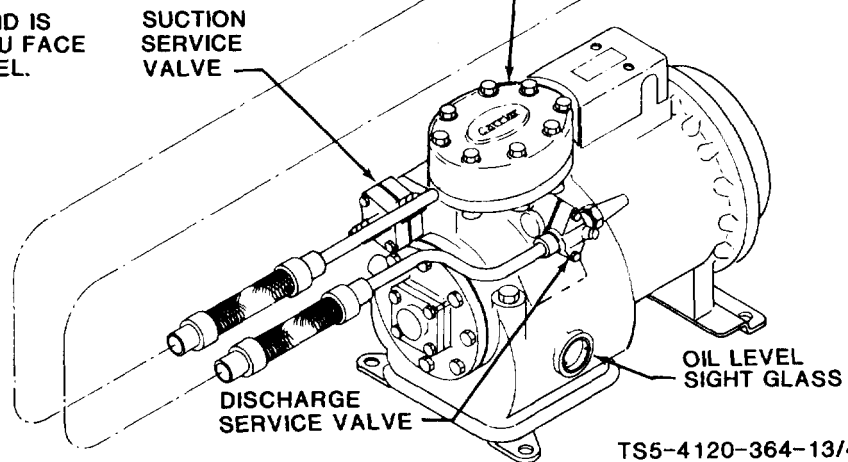

TS5-4120-364-13/4-3

Figure 4-3. Location and function of refrigerant valves



d. Evacuation of the system when unit has lost complete charge. When the system has lost its complete charge, it is very important that the system be completely evacuated before recharging. Proceed as follows:

- (1) Attach charging line to suction service valve port. (See figure 4-2).
- (2) Backseat the discharge service valve and remove the plug from the port.
- (3) Open the suction service valve so both port and compressor are open.
- (4) Open the valve on the refrigerant cylinder and build 30 pounds pressure in the system.
- (5) Test for leaks using available leak detector. If leaks are found, close refrigerant cylinder valve, release system pressure and repair as necessary, then repeat steps (2) through (5). If no leaks are found, proceed with step (6).
- (6) Release pressure in system and replace plug on discharge service valve port.
- (7) Using a vacuum pump, pull a 20 to 25 inch (41 to 64cm) vacuum on refrigerant system, attaching the vacuum pump line to the suction service valve port. Purge with gas from the refrigerant cylinder and again pull a vacuum.
- (8) When a 20 to 25 inch(51 to 64cm) vacuum is reached, backseat the suction service valve.
- (9) Remove the vacuum line.

#### 4-10. CHARGING THE REFRIGERANT SYSTEM WITH A FULL CHARGE.

- a. After completion of system evacuation in accordance with paragraph 4-9, the unit is ready for recharging.
- b. Connect the refrigerant charging hookup as shown in figure 4-2 with a full cylinder of refrigerant R- 12. Weigh the cylinder so that 13 pound 8 ounces can be measured into the system.

#### NOTE

The refrigerant cylinder used for recharging should be equipped with a large capacity filter drier. If available, use recycled refrigerant.

- c. Attach charging line to unit. Do not tighten. Be sure refrigerant cylinder is in upright position so only gas will be drawn off.
- d. Open refrigerant cylinder valve slightly and then close to purge air from the charging line. Tighten charging line on service valve fitting.
- e. Open valve on refrigerant cylinder about 2 turns.

- f. Open the system discharge valve about 2 turns and allow pressure to equalize.
- g. Start unit and run until 13 pounds 18 ounces of refrigerant R-12 is added.
- h. Backseat suction service valve.
- i. Close refrigerant cylinder valve and remove charging line from valve.

4-11. EXPANSION VALVE.

a. Inspect. Inspect the expansion valve located in a bracket on the side of the evaporator coil for damage which would impair serviceability.

b. Adjust

**CAUTION**

Never adjust the expansion valve unless absolutely necessary. When adjusting the expansion valve allow at least 20 minutes between each adjustment. Insure that all panels are in place.

(1) Tape the bulb of a thermometer to the suction line near the sensing element of the expansion valve.

(2) Install a pressure gage to indicate suction pressure.

(3) Operate the unit on cool for approximately 30 minutes to stabilize thermometer reading.

(4) Check thermometer and pressure gage. To the suction pressure, add estimated suction line loss (2 psi). Convert this refrigerant R-12 suction pressure to temperature and subtract from temperature indication of suction line. The superheat should be 10 degrees.

(5) Remove seal cap on side of expansion valve and turn adjusting screw. Turning adjusting screw to the left increases flow and lowers superheat. Turning adjusting screw to the right decreases flow and raises superheat. Four complete turns will raise or lower superheat by approximately 2 degrees.

c. Replace. The expansion valve may be removed from the distributor which is an integral part of the evaporator coil. To remove and replace the expansion valve, see figure 44.

4-12. EVAPORATOR COIL ASSEMBLY .

a. General. The evaporator coil assembly may be removed from its section without disassembly of other sections of the unit. Normally, the expansion valve, distributor, suction header and equalizer line are removed as a part of the evaporator coil assembly. (See figure 4-5).

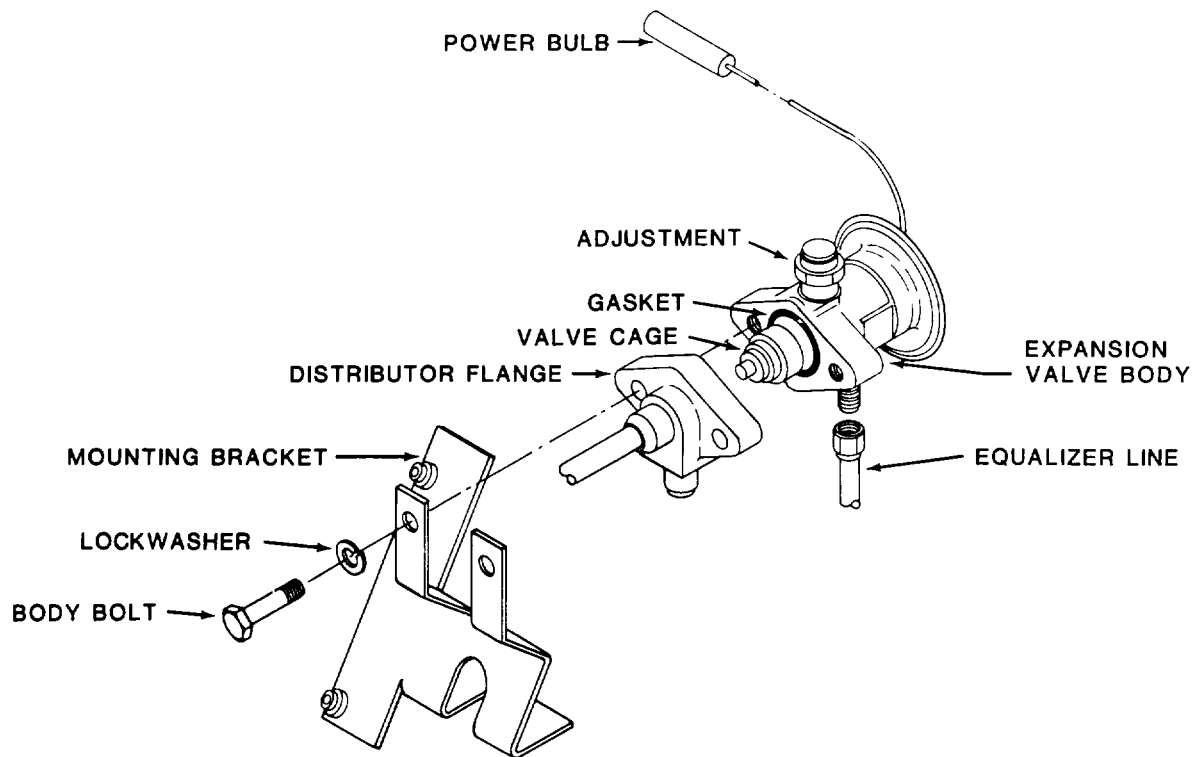

**REMOVAL:**

- (1) REMOVE END PANELS, FRONT PANEL AND AIR FILTER FROM EVAPORATOR COIL SECTION.
- (2) PUMP DOWN REFRIGERANT SYSTEM IN ACCORDANCE WITH PARAGRAPH 4-6.
- (3) CLOSE SHUTOFF VALVES AT BOTH ENDS OF EVAPORATOR COIL.
- (4) DISCONNECT EQUALIZER LINE FROM EXPANSION VALVE BODY.
- (5) FREE EXPANSION VALVE POWER BULB BY REMOVING BLACK INSULATION AND SCREWS IN CLAMP STRAPS, THEN REMOVE VALVE BODY BOLTS.
- (6) LIFT OFF BODY OF EXPANSION VALVE LEAVING DISTRIBUTOR FLANGE IN PLACE ON EVAPORATOR COIL.

**INSTALLATION:**

- (1) POSITION EXPANSION VALVE ASSEMBLY ON DISTRIBUTOR FLANGE AND INSERT BODY BOLTS.
- (2) PUT EXPANSION VALVE POWER BULB IN SAME POSITION ON SUCTION TUBE, ASSURING CLEANLINESS AND GOOD PHYSICAL CONTACT.
- (3) SECURE POWER BULB BY TIGHTENING SCREWS IN CLAMP STRAPS AND WRAP WITH BLACK INSULATION.
- (4) CONNECT EQUALIZER LINE TO EXPANSION VALVE WITH FLARE NUT.
- (5) PURGE OPENED REFRIGERANT SYSTEM IN ACCORDANCE WITH PARAGRAPH 4-9 AND OPEN SHUTOFF VALVES.
- (6) REPLACE PANELS AND AIR FILTER.

TS5-4120-364-1314-4

Figure 4-4. Expansion valve, removal and replacement

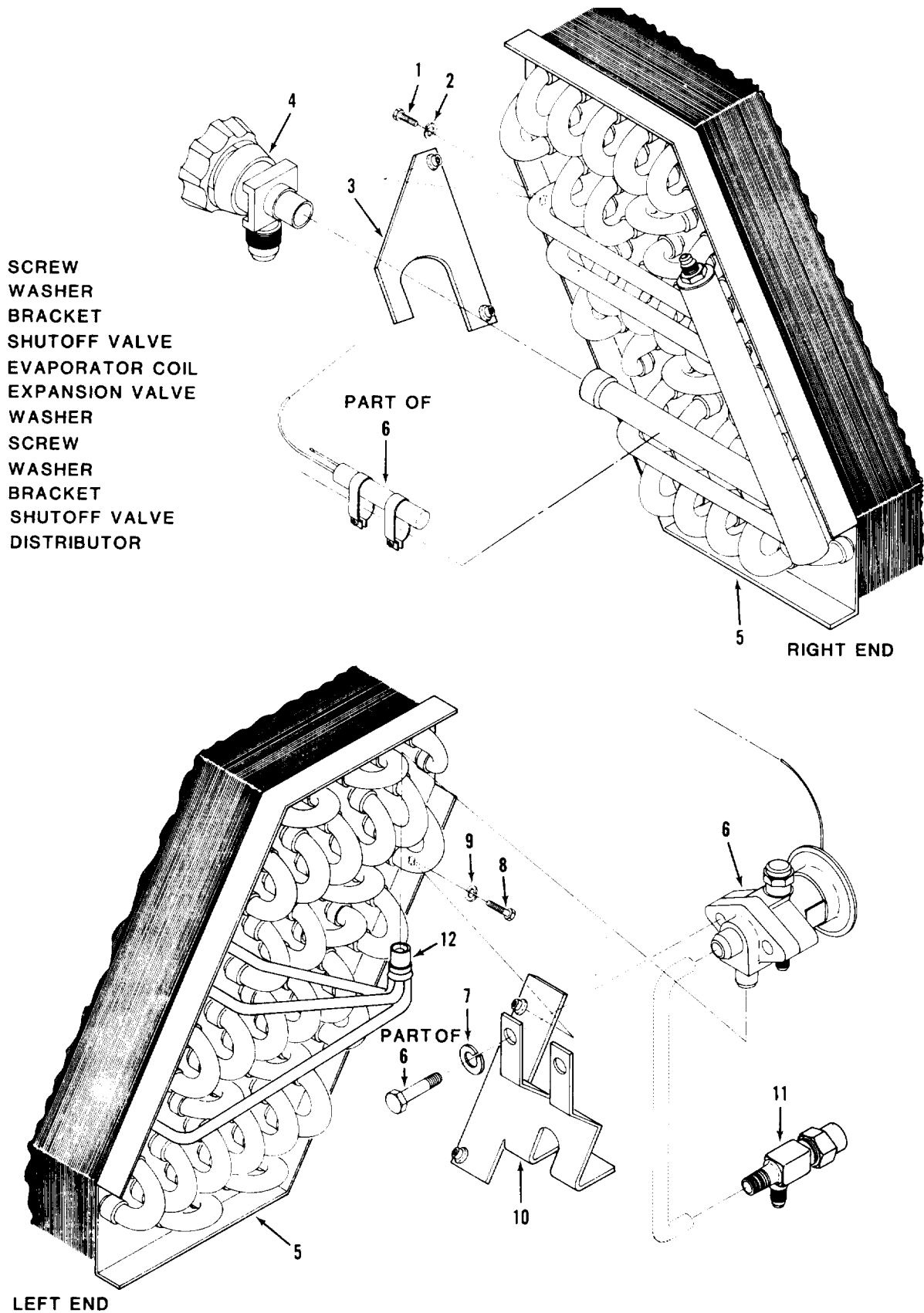

Figure 4-5. Evaporator coil and components

TS5-4120-364-13/4-5

b. Inspection. Inspect the evaporator coil assembly for damage which would impair serviceability.

c. Removal.

(1) Refer to figure 3-5 and remove end panels, front panel and air filter from the evaporator coil section by turning fasteners (4) one-quarter turn counterclockwise.

(2) Pump down the refrigerant system in accordance with paragraph 4-6 and close shutoff valves at both ends of the evaporator coil.

(3) Loosen flare nuts on liquid and suction lines.

(4) Unbolt front support (23, 31, figure 4-6) and rear supports (14, 29).

(5) Lift evaporator coil assembly from frame.

d. Replace. Refer to figure 4-5 and repair or replace evaporator coil components as required.

e. Installation.

(1) Place evaporator coil assembly in position in frame.

(2) Place front supports (23, 31, figure 4-6) and rear supports (14, 29) and bolt them to the evaporator coil assembly and to frame.

(3) Reconnect flare nuts at liquid and suction lines.

(4) Purge opened refrigerant system of air in accordance with paragraph 4-9 and open shutoff valves.

(5) Refer to figure 3-5 and replace air filter and panels.

#### 4-13. FILTER DRIER.

a. General. The filter drier (12, figure 4-7) is located in the condenser fan section of the air conditioner. It is in the refrigerant liquid line to remove and retain any foreign substance in the refrigerant. The filter drier should not be replaced with equipment of lesser capacity than the original equipment. Install a new filter drier whenever the refrigerant system has been opened.

b. Removal.

(1) Refer to figure 3-7 and remove panels from the condenser fan section by turning fasteners (8) one-quarter turn counterclockwise and removing screws (22) and washers (23).

(2) Pump down the refrigerant system in accordance with paragraph 4-6 and close liquid line shutoff valve.

(3) Disconnect tubes from top and bottom of filter drier (12, figure 4-7) by loosening flare nuts (1),

- |               |                |             |
|---------------|----------------|-------------|
| 1. BAFFLE     | 12. GROMMET    | 23. BRACKET |
| 2. SCREW      | 13. CLAMP      | 24. SCREW   |
| 3. WASHER     | 14. BRACKET    | 25. SCREW   |
| 4. GROMMET    | 15. NUT        | 26. BRACKET |
| 5. BAFFLE     | 16. EXTENSION  | 27. CLAMP   |
| 6. LOCKWASHER | 17. SCREW      | 28. BAFFLE  |
| 7. NUT        | 18. DRAIN PAN  | 29. BRACKET |
| 8. NUT        | 19. INSULATION | 30. SCREW   |
| 9. LOCKWASHER | 20. BRACKET    | 31. BRACKET |
| 10. SCREW     | 21. SCREW      | 32. BAFFLE  |
| 11. BAFFLE    | 22. WASHER     | 33. TUBE    |

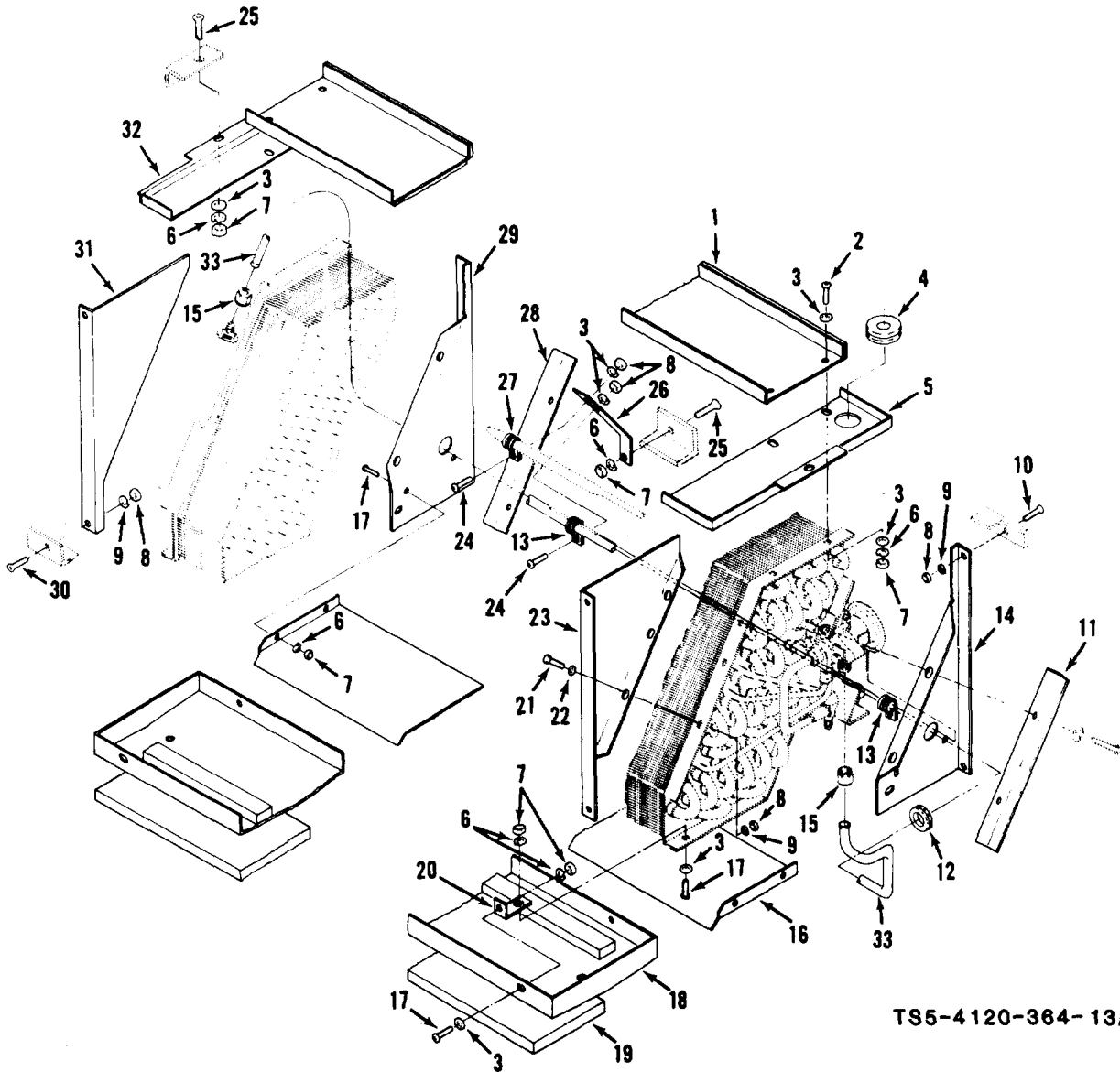

TS5-4120-364-13/4-6

Figure 4-6. Evaporator coil mounting

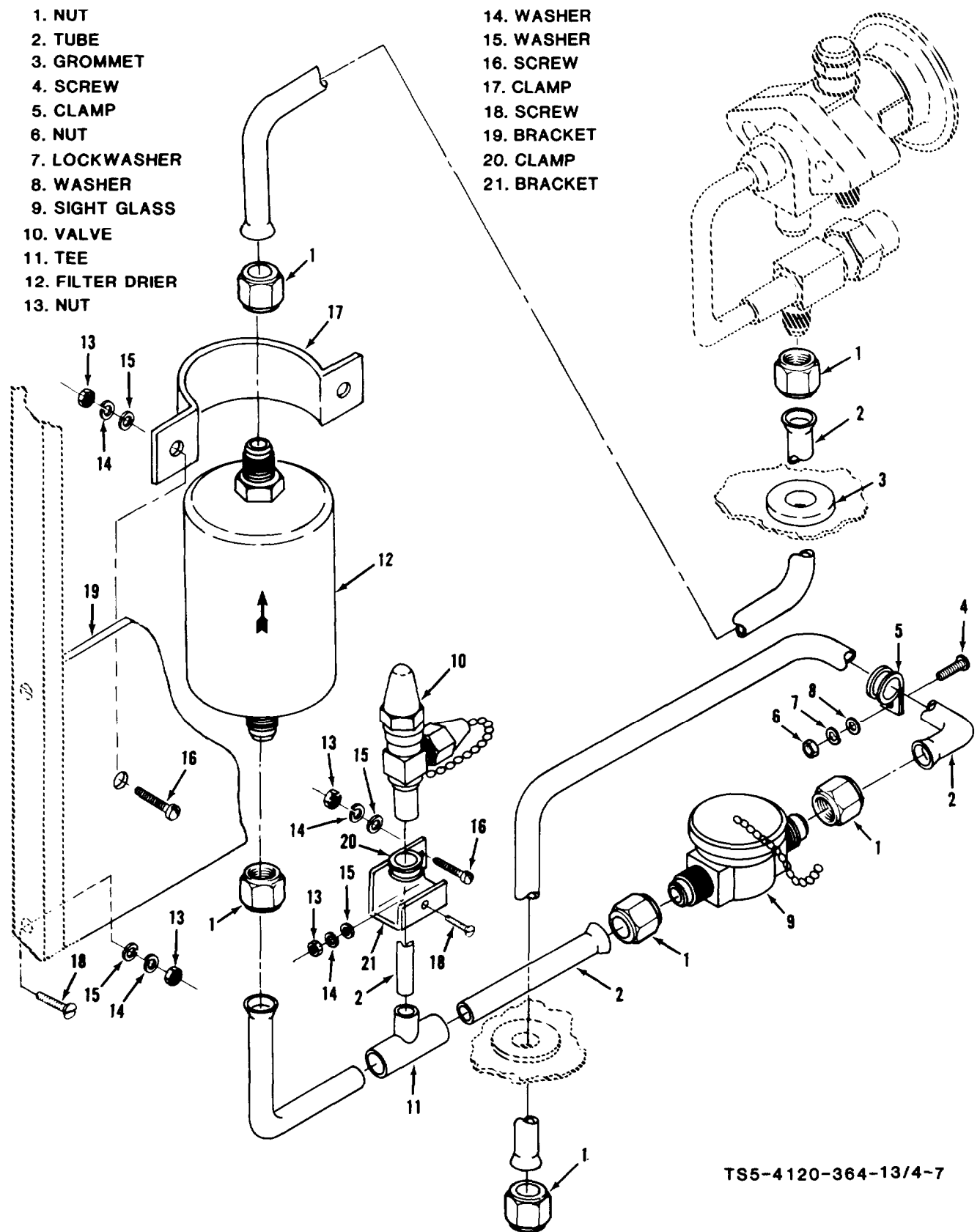

Figure 4-7. Filter drier, sight glass and mountings

(4) Remove nuts (13), washers (14, 15), screws (16) and clamp (17), then remove filter drier (12) from unit.

c. Installation.

(1) Position filter drier (12) on bracket (19) with direction of flow arrow pointing up. Secure filter drier with clamp (17), screws (16), washers (15, 14) and nuts (13).

(2) Connect tubes with flare nuts (1) to inlet and outlet connections on filter drier.

(3) Purge opened refrigerant system in accordance with paragraph 4-9.

(4) Open shutoff valves and return unit to service.

(5) Refer to figure 3-7 and install panels.

4-14. SIGHT GLASS ASSEMBLY.

a. General. The refrigerant sight glass (9, figure 4-7) is located on the left end of the condenser fan section as YOU face the control panel. It is used to indicate a low refrigerant charge.

b. Removal.

(1) Pump down the refrigerant system in accordance with paragraph 4-6.

(2) Remove end panel from left end of condenser fan section by turning fasteners one-quarter turn counterclockwise.

(3) Close shutoff valve and outlet valve in liquid line. (See figure 4-3).

(4) Loosen flare nuts (1, figure 4-7) and remove sight glass (9) from unit.

c. Installation.

(1) Position sight glass (9) in unit and connect and tighten flare nuts

(2) Purge opened section of refrigerant system in accordance with paragraph 4-9.

(3) Charge the refrigerant system in accordance with paragraph 4-10,

(4) Open valves to restore unit to service,

(5) Replace end panel.

4-15. CONDENSER COIL ASSEMBLY.

a. General. The condenser coil may be removed from its section without



disassembly of other sections of the unit. Caution should be exercised to prevent damage to fins. (See figure 4-8).

b. Inspection. Inspect condenser coil assembly for damage which would impair serviceability.

c. Removal.

(1) Refer to figure 3-13 and remove front, rear and end panels from condenser coil section by turning fasteners (9) one-quarter turn counterclockwise.

(2) Pump down the refrigerant system in accordance with paragraph 4-6 and close shutoff valves to isolate condenser coil.

(3) Disconnect compressor discharge line at condenser coil, and condenser outlet at service valve.

(4) Remove center vertical support bracket (1).

(5) Refer to figure 4-8 and unbolt condenser support brackets (2, 10, 11, 26) from condenser coil and frame, then lift condenser coil out of the front of the unit.

d. Installation.

(1) Position condenser coil (1) in frame.

(2) Attach support brackets (2, 10, 11, 26) and bolt to frame.

(3) Attach and bolt center vertical support (1, figure 3-10) to frame.

(4) Connect refrigerant lines.

(5) Purge opened refrigerant system in accordance with paragraph 4-9.

(6) Open valves and return unit to service.

(7) Replace panels.

#### **4-16. MOTOR COMPRESSOR ASSEMBLY.**

a. General. The motor compressor assembly is a semi-hermetically sealed unit and may be removed as an assembly for replacement without disassembly of other sections of the air conditioner. Before removing the rotor compressor assembly, disconnect external power source from the air conditioner. Remove front, rear and side panels from the compressor section by turning fasteners one-quarter turn counterclockwise. Refer to figure 4-9 and 4-10 for removal and installation of rotor compressor assembly .

b. After replacement of rotor compressor assembly, proceed as follows:

(1) Refer to paragraph 4-5 and install service gages.

(2) Turn unit on.

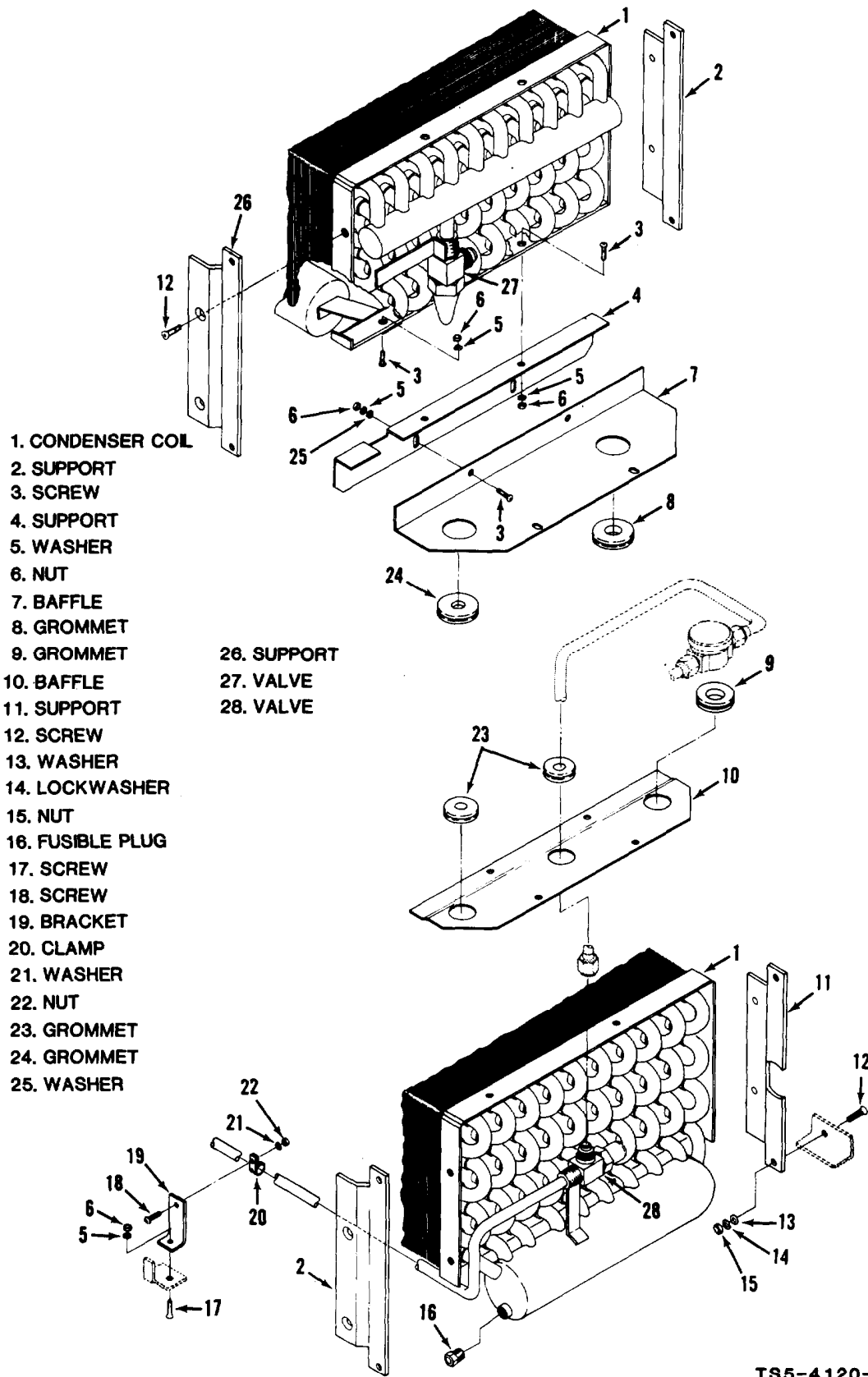

TS5-4120-364-13/4-8

Figure 4-8. Condenser coil and mounting components

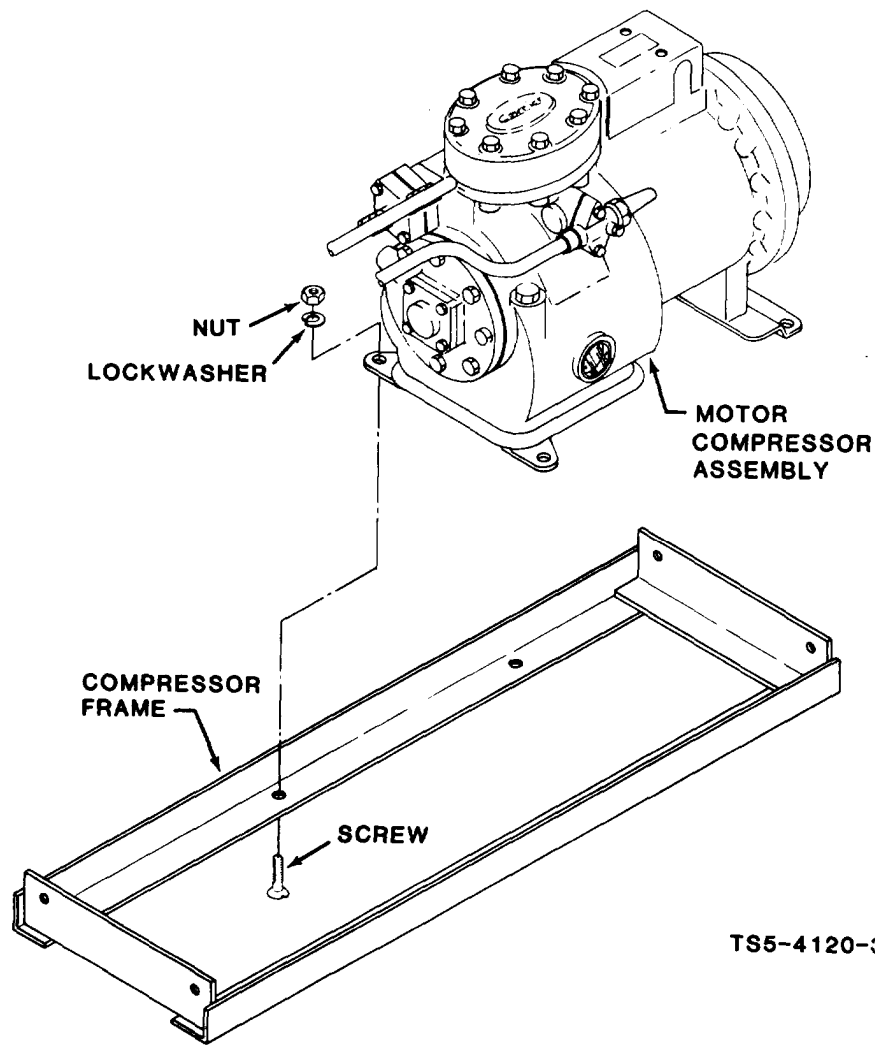
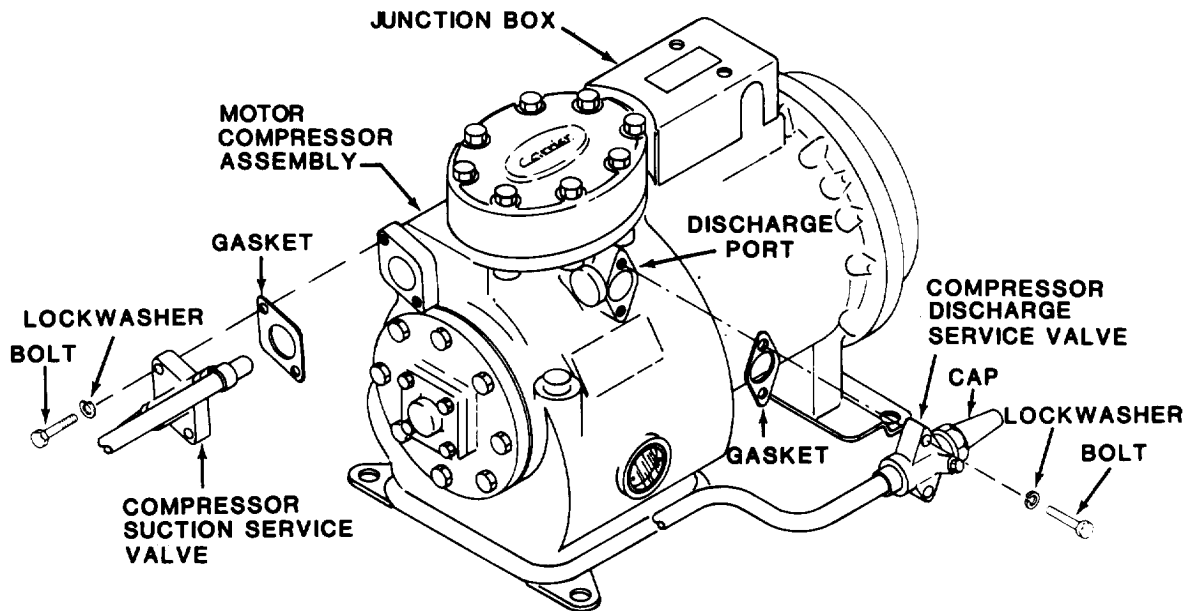

Figure 4-9. Motor compressor removal



**REMOVAL**

- (1) REMOVE CAPS AND FRONT SEAT BOTH SUCTION AND DISCHARGE SERVICE VALVES ON COMPRESSOR BY TURNING STEM CLOCKWISE AS FAR AS THEY WILL GO.
- (2) LOOSEN MOUNTING BOLTS ON BOTH SERVICE VALVES JUST ENOUGH TO ALLOW REFRIGERANT TO ESCAPE THROUGH VALVE MOUNTS.
- (3) AFTER ALL PRESSURE HAS BEEN RELIEVED, REMOVE MOUNTING BOLTS AND VALVES FROM MOTOR COMPRESSOR.
- (4) REMOVE FOUR NUTS, WASHERS AND SCREWS, THEN LIFT MOTOR COMPRESSOR UP AND OUT OF FRAME.
- (5) REMOVE JUNCTION BOX COVER. TAG AND DISCONNECT EIGHT LEADS FROM INSIDE JUNCTION BOX.
- (6) REMOVE LOCK NUT ON WIRE CLAMP IN JUNCTION BOX, THEN REMOVE WIRES AND CLAMP FROM BOX.

**INSTALLATION**

- (1) INSTALL WIRES AND CLAMP IN JUNCTION BOX AND RECONNECT WIRES.
- (2) LIFT MOTOR COMPRESSOR ASSEMBLY UP AND INTO FRAME. SECURE WITH FOUR SCREWS, WASHERS AND NUTS.
- (3) REMOVE BOLTS AND COVER PLATES FROM BOTH VALVE PORTS ON NEW MOTOR COMPRESSOR.
- (4) REINSTALL SERVICE VALVES WITH NEW GASKETS. TIGHTEN DISCHARGE SERVICE VALVE ONLY. LEAVE SUCTION SERVICE VALVE SLIGHTLY LOOSE.
- (5) CRACK DISCHARGE SERVICE VALVE BY TURNING COUNTERCLOCKWISE TO BLEED REFRIGERANT INTO COMPRESSOR TO PURGE AIR THROUGH LOOSE SERVICE VALVE.
- (6) WHILE REFRIGERANT IS ESCAPING SERVICE VALVE, TIGHTEN MOUNTING BOLTS. THEN CRACK VALVE SLIGHTLY TO PURGE AIR FROM VALVE.
- (7) BACK SEAT BOTH SERVICE VALVES BY TURNING FULL COUNTERCLOCKWISE.
- (8) TURN DISCHARGE SERVICE VALVE 1-1/2 TURNS CLOCKWISE TO ALLOW PRESSURE TO REACH THE HIGH PRESSURE CUTOUT SWITCH.

TS5-4120-364-13/4-10

**Figure 4-10. Removal and installation of motor compressor assembly**

(3) Check sight glass. If sight glass appears bubblely or frothy, add refrigerant R-12 as required in accordance with paragraph 4-8 for a clear sight glass.

(4) Check pressures. Pressure should be as given in table 4-2.

**Table 4-2. Refrigerant Pressures**

CONDITIONED AIR EXTERNAL STATIC PRESSURE	RETURN AIR TEMPERATURE	AMBIENT TEMPERATURE	COMPRESSOR SUCTION PRESSURE (PSIG)	COMPRESSOR DISCHARGE PRESSURE (PSIG)
0.25 in H2O	90°F DB/ 75°F WB	125°F	60 ±2	241 ±5
0.25 in H2O	80°F DB/ 67°F WB	95°F	43 ±2	170 ±5

4-17. MOTOR COMPRESSOR

a. General.

(1) Where compressor components are shown in figure 4-11, they are in normal order of removal from the compressor.

(2) After disassembly, clean all parts with solvent. Use mineral spirits, white gasoline or naphtha.

(3) Before reassembly, coat all parts with compressor oil and clean and inspect all gasket surfaces. Replace all gaskets with new specified gaskets mated with compressor oil.

(4) After reassembly, evacuate compressor and open suction and discharge valves. Restart compressor and adjust refrigerant charge.

(5) Motor Replacement. Startor and rotor are not field replaceable. Stator is a press fit into motor housing. If compressor motor is damaged, replace rotor compressor assembly.

(6) Pump End Main Bearing. This main bearing is a machined part of the aluminum oil pump and bearing casting. If after disassembly, bearing is scored or worn, replace complete bearing head.

(7) Crankcase and Motor End Main Bearings. These are not field replaceable. If bearings are worn or damaged, replace rotor compressor assembly.

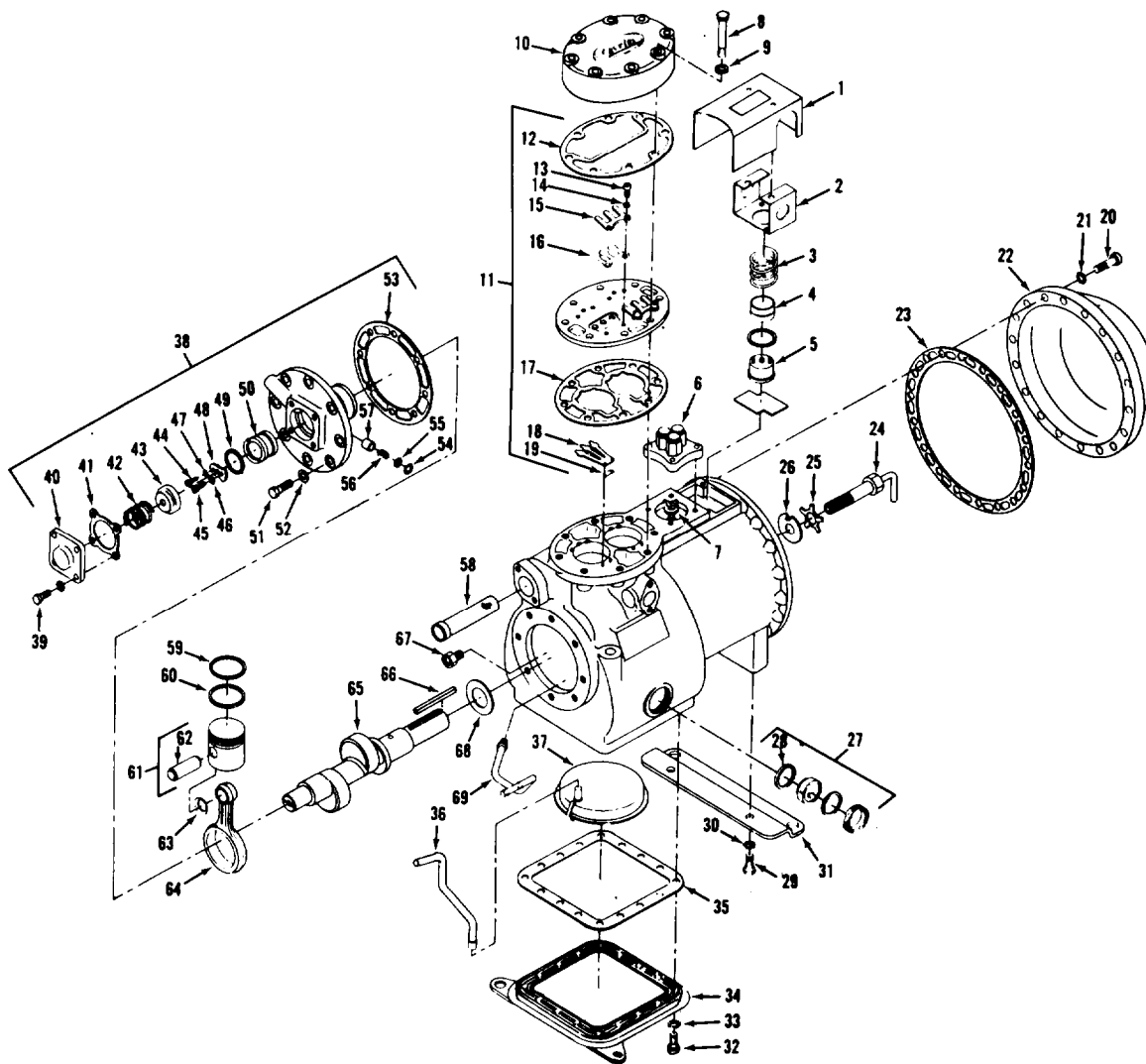

- |                         |                         |                           |
|-------------------------|-------------------------|---------------------------|
| 1. COVER                | 24. EQUALIZER           | 47. LOCKWASHER            |
| 2. BRACKET              | 25. LOCKWASHER          | 48. DRIVE SEGMENT         |
| 3. SPRING               | 26. LOCKWASHER          | 49. RETAINING RING        |
| 4. INSULATOR            | 27. SIGHT GLASS PACKAGE | 50. PUMP ROTOR            |
| 5. THERMOSTAT           | 28. GASKET              | 51. SCREW                 |
| 6. TERMINAL PLATE       | 29. BOLT                | 52. LOCKWASHER            |
| 7. GROMMET              | 30. WASHER              | 53. GASKET                |
| 8. BOLT                 | 31. FOOT                | 54. RETAINING RING        |
| 9. WASHER               | 32. SCREW               | 55. GUIDE                 |
| 10. CYLINDER HEAD       | 33. GASKET              | 56. SPRING                |
| 11. VALVE PLATE PACKAGE | 34. BOTTOM PLATE        | 57. PUMP VANE             |
| 12. GASKET              | 35. GASKET              | 58. STRAINER              |
| 13. SCREW               | 36. TUBE                | 59. RING                  |
| 14. LOCKWASHER          | 37. FILTER              | 60. OIL RING              |
| 15. VALVE STOP          | 38. BEARING HEAD KIT    | 61. PISTON & PIN PACKAGE  |
| 16. VALVE DISC          | 39. SCREW               | 62. PIN                   |
| 17. GASKET              | 40. COVER PLATE         | 63. SPRING WASHER         |
| 18. VALVE DISC          | 41. GASKET              | 64. PISTON ROD            |
| 19. SPRING              | 42. SPRING              | 65. ECCENTRIC SHAFT       |
| 20. BOLT                | 43. GUIDE               | 66. DRIVE KEY             |
| 21. GASKET              | 44. SCREW               | 67. CHECK VALVE           |
| 22. END COVER           | 45. SCREW               | 68. THRUST WASHER         |
| 23. GASKET              | 46. LOCKWASHER          | 69. RELIEF VALVE ASSEMBLY |

Figure 4-11. Motor compressor assembly, exploded view TS5-4120-364-13/4-11

b. Removal. Refer to paragraph 4-16 and remove the motor compressor assembly from the air conditioner.

c. Disassembly.

(1) Oil filter screen and relief valve. If oil pressure is low, remove and check the oil filter screen and relief valve. The screen and valve are accessible through bottom cover plate. Proceed as follows:

(a) Remove screws (32, figure 4-11), gaskets (33), bottom plate (34), gasket (35) and filter screen (37).

(b) Unscrew relief valve assembly (69) from motor partition plate.

(2) Inspect.

(a) Inspect strainer for holes and dirt. Clean with solvent or replace.

(b) Inspect relief valve assembly for clogging or stuck plunger. Clean with solvent or replace.

(3) Installation.

(a) Screw relief valve into motor partition plate.

(b) Position filter screen in bottom of compressor and connect to oil suction tube (36).

(c) Install new gasket (35), bottom plate (34) and secure with screws (32) and gaskets (33).

(4) Oil Pump and Bearing Head. The oil pump assembly (38) is contained in the pump end bearing head casting. The pump end main bearing is a machine part of this casting. An insert bearing is not used or required.

(a) Removal.

1. Remove bearing head assembly (38) from crankcase by removing screws (51) and washers (52). Then remove oil pump vane assemblies (54 through 57) from both sides of bearing head.

2. Remove in sequence: oil pump rover (40), oil feed guide retaining spring (42), oil feed guide (43), and pump drive segment (48).

3. Slide pump rotor (50) out of bearing head by pushing against bearing side of rotor.

4. Remove retaining ring (49) from pump rotor (50).

(b) Replace.

1. Install rotor retaining ring (49) in ring groove of pump rotor

(50) with chamfered edge toward compressor. Compress the retaining ring and insert pump rotor into bearing head.

2. On each side of bearing head, insert pump vane (57), pump vane spring (56) and spring guide (55) into cavity in bearing head. Press retaining ring (54) into cavity with flat side outward until ring snaps into ring groove.

3. Bolt bearing head to crankcase with new gasket (53) using screws (51) and new gaskets (52).

4. Place pump drive segment (48) into position and secure to end of crankshaft (65) with cap screws (44, 45) and lockwashers (46, 47).

5. Insert oil feed guide (43), with large diameter inward, and place guide retainer spring (42) over small diameter of guide (43).

6. Install new gasket (41) and oil pump cover (40) and secure with screws (39).

(5) Cylinder Head Removal. Remove cylinder head by removing cap screws (8) and washers (9) and prying up on side between cylinder head and valve plate to break head loose from valve plate. Do not strike cylinder head to break it loose.

(6) Inspection. Inspect cylinder head for warping, cracks and damage to gasket surface.

(7) Replace. When replacing cylinder head, torque cap screws 30 to 35 lb-ft to prevent high to low side leak in center portion of cylinder head gasket.

#### 4-18. COMPRESSOR MOTOR BURNOUT.

a. General. If a hermetic motor burns out, the stator winding decomposes forming carbon, water and acid which contaminate refrigerant systems. These contaminants must be removed from the system to prevent repeated rotor failures.

b. Minimum System Clean-Up Procedure.

(1) Close compressor suction and discharge service valves and bleed refrigerant from compressor. Save remaining refrigerant in the system.

(2) Check control box for welded contactor contacts, welded overload contacts or burned out heater elements. Check terminal plate for burned or damaged terminals, insulation and shorted or grounded terminals. Repair or replace parts where necessary.

(3) Remove suction and discharge shutoff valve bolts and all other connections to damaged compressor. Remove damaged compressor and replace with new compressor. Replace-liquid-line filter drier with a filter drier of one size larger.

(4) Purge new compressor.

(5) Place compressor in operation. After 2 to 4 hours of operation, check compressor oil for signs of discoloration and/or acidity. If oil shows signs of contamination, replace oil charge, filter driers, and clean suction strainer with solvent.



Repeat this procedure until oil stays clean and acid free for 48 hours of operation.

#### 4-19. HIGH PRESSURE CUTOOUT SWITCH.

a. General. The high pressure cutout switch (figure 4-12) is located in the compressor section. It is preset at the factory to trip at 280 psi, and is wired into the circuit to the thermostat so that operation of all rotors is stopped if discharge pressure in the refrigerant system reaches that point. The high pressure switch cannot be repaired and if defective, it must be replaced.

b. Adjust. If the high pressure switch requires adjustment, it may be adjusted by means of the shaft protruding from the top of the switch housing. A scale, located on the front of the switch housing indicates the pressure at which the switch is set to trip. Turn the shaft right or left to set the pressure desired as indicated on the scale.

c. Removal.

(1) Refer to figure 3-12 and remove the rear panel of the compressor section by turning fasteners (14) one-quarter turn counterclockwise.

(2) Backseat the compressor discharge service valve and disconnect high pressure line flare nut at compressor.

(3) Disconnect and tag electrical leads coming from the high pressure switch, then remove screws (2, figure 4-12) and high pressure cutout switch (3).

d. Installation.

(1) Mount high pressure cutout switch (3) in position on bracket (1) and secure with screws (2).

(2) Connect electrical leads.

(3) Attach high pressure line with flare nut to compressor but do not tighten nut at this time.

(4) Open compressor discharge service valve slightly to purge air from high pressure line, then tighten flare-nut.

(5) Open compressor discharge service valve all the way.

(6) Install rear panel on compressor section by turning fasteners one-quarter turn clockwise.

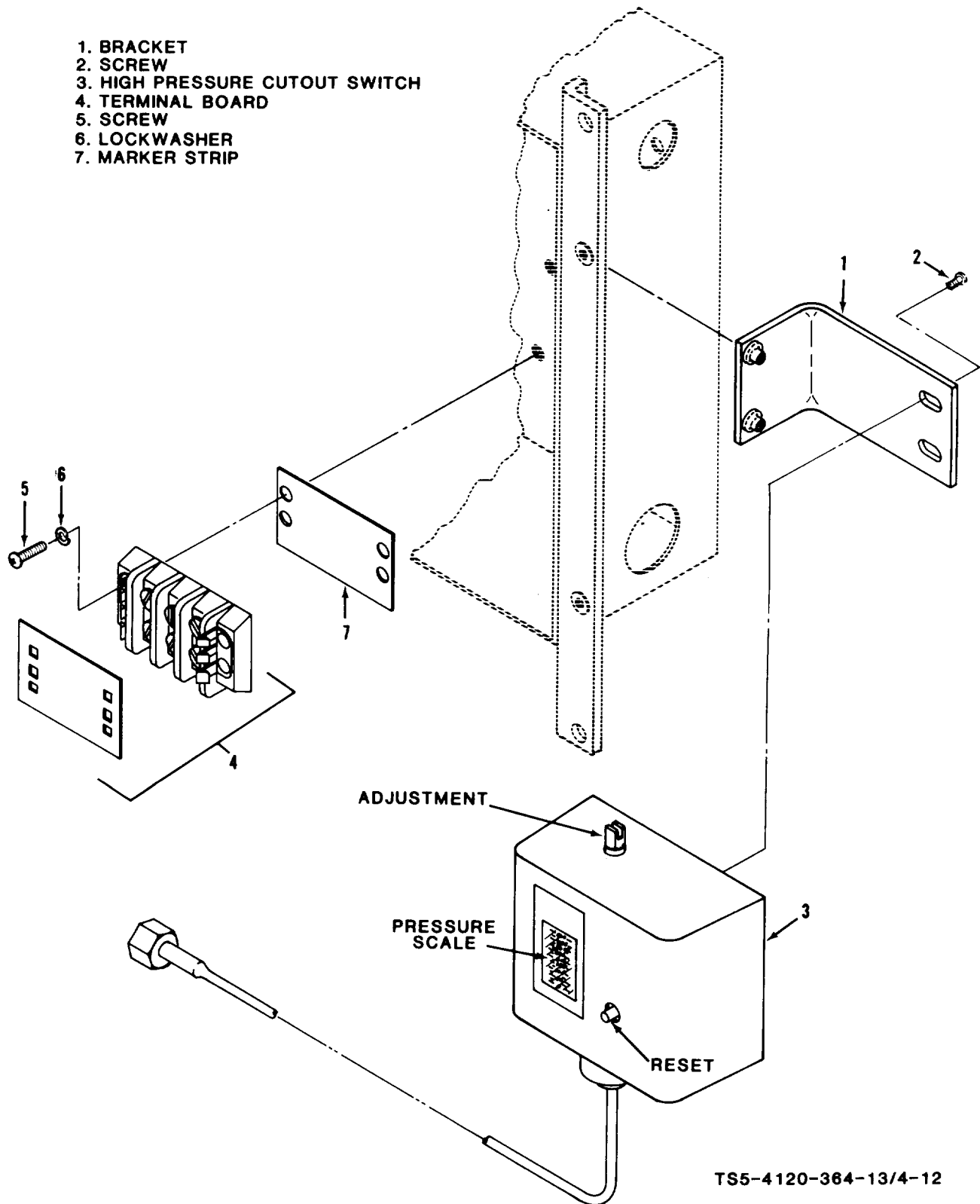

Figure 4-12. High pressure cutout switch

APPENDIX A

REFERENCES

- |      |                     |  |
|------|---------------------|--|
| A-1. | Administration      |  |
|      | TM 740-90-1         | Administrative Storage of Equipment  |
| A-2. | Fire Protection     |  |
|      | TB 5-4200-200-10    | Hand Portable Fire Extinguisher, Approved for Army Users.  |
|      | TM 5-687            | Repair and Utilities: Fire Protection Equipment and Appliances: Inspection, Operations, and Preventive Maintenance |
| A-3. | Demolition          |  |
|      | TM 750-244-3        | Procedure for Destruction of Equipment   |
| A-4. | Painting            |  |
|      | TM 43-0139          | Painting Instructions for Field Use  |
| A-5. | Maintenance         |  |
|      | TM 5-764            | Electric Motor and Generator Repair  |
|      | TM 5-4120-364-23P   | Repair Parts and Special Tools List  |
|      | TM 38-250           | Crate Fabrication  |
|      | TM 38-750           | The Army Maintenance Management System   |
| A-6. | Supply Publications |  |
|      | C9100-IL            | Fuels, Lubricants, Oils and Waxes  |



## APPENDIX B

## COMPONENTS OF END ITEM LIST

## Section I. Introduction

## B-1. SCOPE.

This appendix lists Integral Components of and Basic Issue Items (BII) for the air conditioner to help you inventory items required for safe and efficient operation.

## B-2. GENERAL.

The components of end item list are divided into the following sections:

a. SECTION II. Integral Components of the End Item.

These items, when assembled, comprise the air conditioner and must accompany it whenever it is transferred or turned in. These illustrations will help you identify these items.

b. SECTION III. Basic Issue Items.

These are minimum essential items required to place the air conditioner in operation, to operate it and to perform emergency repairs. Although shipped separately packed, they must accompany the air conditioner during operation and whenever it is transferred between accountable officers. The illustrations will assist you with hard to find items. This manual is your authority to requisition replacement BII based on Table(s) of Organization and Equipment (TOE) /Modification Table of Organization and Equipment (MTOE) authorization of the end item.

## B-3. EXPLANATION OF COLUMNS.

a. ILLUSTRATION. This column is divided as follows:

(1) FigureNumber. Indicates the figure number of the illustration on which the item is shown (if applicable).

(2) Item Number. The number used to identify item called out in the illustration.

b. NATIONAL STOCK NUMBER (NSN). Indicates the national stock number assigned to the end item which will be used for requisitioning.

c. PART NUMBER P/N. Indicates the primary number used by the manufacturer which controls the design and characteristics of the item by means of its engineering drawings, specifications, standards and inspection requirements to identify an item or range of items.

d. DESCRIPTION. Indicates the federal item name and, if required, a minimum description to identify the item.

e. LOCATION. The physical location of each item listed is given in this

column. The lists are designed to inventory all items in one area of the major item before moving on to an adjacent area.

f. USABLE ON CODE. "USABLE ON" codes are included to help you identify which component items are used on the different models. Identification of the codes used in this list are:

CODE

USED ON

g. QUANTITY REQUIRED (QTY REQD). This column list the quantity of each item required for a complete major item.

h. QUANTITY. This column is left blank for use during inventory. Under the received column, list the quantity you actually receive on your major item. The date columns are for use when you inventory the major item at a later date, such as for shipment to another site.

Section II  
INTEGRAL COMPONENTS OF END ITEM

(1) ILLUSTRATION FIGURE NO.	(2) NATIONAL STOCK NUMBER	(3) PART NO. & FSCM	(4) DESCRIPTION	(5) LOCATION	(6) USABLE ON CODE	(7) QTY REQD	(8)		
							RCV,D	DATE	DATE
3-2		13217E0025-5 (97403)	Jumper wire. MFD From; Wire, elec. (1 Ft. reg.) M5086/1-14-9 (81349) Term. Lug (1 ea. reg.) MS25036-153 (96906) Term. Lug (1 ea reg) MS25039-108 (96906)			1			
3-2	5999-00-977-4399	13217E0139-3 (97403) 42417 (04009)	Heater, Thermal, 120 VAC.			2			
3-2	5935-00-850-5584	MS3106R24-10S	Electrical Connector (J-1)			1			
	5306-00-056-3536	MS51937-2 (86906)	Lifting Eye Bolt. Order for complete assy.: 4 ea, Lock- washer, MS35998-45 (96906), 4 ea Nut, MS35649, (96906)			4			

Section III  
BASIC ISSUE ITEMS

(1) ILLUSTRATION		(2) NATIONAL STOCK NUMBER	(3) PART NO. & FSCM	(4) DESCRIPTION	(5) LOCATION	(6) USABLE ON CODE	(7) QTY REQD	(8)		
FIGURE NO.	ITEM NO.							RCV,D	DATE	DATE
		5220-00-559-9618		Case, Manual Department of the Army Technical Manual: Operator, Organiza- tional, and Direct Support Maintenance Manual. TM 5-4120-364-13			1			
							1			



## APPENDIX C

## MAINTENANCE ALLOCATION CHART

## Section I. Introduction

## C-1. GENERAL.

a. This section provides a general explanation of all maintenance and repair functions authorized at various maintenance levels.

b. The Maintenance Allocation Chart (MAC) in Section II designates overall responsibility for the performance of maintenance functions on the identified end item or component. The implementation of the maintenance functions upon the end item or component will be consistent with the assigned maintenance functions.

c. Section III list the special tools and test equipment required for each maintenance function as referenced from Section II.

d. Section IV contains supplemental instructions on explanatory notes for a particular maintenance function.

## C-2. MAINTENANCE FUNCTIONS.

a. INSPECT. To determine serviceability of an item by comparing its physical, mechanical and/or electrical characteristics with established standards through examination.

b. TEST. To verify serviceability and detect incipient failure by measuring mechanical or electrical characteristics of an item and comparing those characteristics with prescribed standards.

c. SERVICE. Operations required periodically to keep an item in proper operating condition, i.e., to clean (decontaminate), to preserve, drain, to paint, or to replenish fuel, lubricants, hydraulic fluids, or compressed air supplies.

d. ADJUST. To maintain within prescribed limits, by bringing into proper or exact-position, or by setting the operating characteristics to be within specified parameters.

e. ALIGN. To adjust specified variable elements of an item to bring about optimum or desired performance.

f. CALIBRATE. To determine and cause corrections to be made or to be adjusted on instruments or test measuring and diagnostic equipments used in precision measurement. Consists of comparison of two instruments, one of which is a certified standard of known accuracy, to detect and adjust any discrepancy in the accuracy of the instrument being compared.

g. INSTALL. The act of emplacing, seating, or fixing into position an item, part or module (component or assembly) in a manner to allow the proper functioning of an equipment or system.

**h. REPLACE.** The act of substituting a serviceable like type part, subassembly or module (component or assembly) for an unserviceable counterpart.

**i. REPAIR.** The application of maintenance services (inspect, test, service, adjust, align, calibrate, or replace) or other maintenance actions (welding, grinding, riveting, straightening, facing, remachining or resurfacing) to restore serviceability to an item by correcting specific damage, fault, malfunctions, or failure in a part, sub-assembly, module (component or assembly), end item or system.

**j. OVERHAUL.** That maintenance effort (service/action) necessary to restore an item to a completely serviceable/operational condition as prescribed by maintenance standards (i.e., DMWR) in appropriate publications. Overhaul is normally the highest degree of maintenance performed by the Army. Overhaul does not normally return an item to like new condition.

**k. REBUILD.** Consists of those services/actions necessary for the restoration of unserviceable equipment to a like new condition in accordance with original manufacturing standards. Rebuild is the highest degree of material maintenance applied to Army equipment. The rebuild operation includes the act of returning to zero those measurements (hours/miles, etc.), considered in classifying Army equipment/components.

**C-3. COLUMN ENTRIES USED IN THE MAC.**

**a. COLUMN 1, GROUP NUMBER.** Column 1 lists group numbers, the purpose of which is to identify components, assemblies, sub-assemblies, and modules with the next higher assembly.

**b. COLUMN 2, COMPONENT/ASSEMBLY.** Column 2 contains the names of components, assemblies, sub-assemblies, and modules for which maintenance is authorized.

**c. COLUMN 3, MAINTENANCE FUNCTIONS.** Column 3 lists the functions to be performed on the item listed in Column 2, (For a detailed explanation of these functions, see paragraph C-2.)

**d. COLUMN 4, MAINTENANCE LEVEL.** Column 4 specifies, by the listing of a "work time" figure in the appropriate subcolumn(s), the lowest level of maintenance authorized to perform the functions listed in Column 3. This figure represents the active time required to perform the maintenance functions at the indicated level of maintenance. If the number or complexity of the tasks within the listed maintenance functions vary at different maintenance levels, appropriate "work time" figures will be shown for each level. The number of man-hours specified by the "Work time" figure represents the average time required to restore an item (assembly, sub-assembly, component or module, end item or system) to a serviceable condition. The symbol designation for the various maintenance levels are as follows:

- C . . . . . Operator or Crew
- O . . . . . Organizational Maintenance
- F . . . . . Direct Support Maintenance
- H . . . . . General Support Maintenance

D . . . . . Depot Maintenance

e. COLUMN 5, TOOLS AND EQUIPMENT. Column 5 specifies, by code, those common tools sets (not individual tools) and special tools, test, and support equipment required to perform the designated function.

f. COLUMN 6, REMARKS. This column shall contain in letter code in alphabetical order which shall be keyed to the remarks contained in Section IV.

C-4. COLUMN ENTRIES USED IN TOOL AND TEST EQUIPMENT REQUIREMENTS.

a. COLUMN 1, TOOL OR TEST EQUIPMENT REFERENCE CODE. The tool and test equipment reference code correlates with a maintenance function on the identified end item or component.

b. COLUMN 2, MAINTENANCE LEVEL. The lowest level of maintenance authorized to use the tool or test equipment.

c. COLUMN 3, NOMENCLATURE. Name or identification of the tool or test equipment.

d. COLUMN 4, NATIONAL/NATO STOCK NUMBER. The National or NATO stock number of the tool or test equipment.

e. COLUMN 5, TOOL NUMBER. The manufacturer's part number.

C-5. EXPLANATION OF COLUMNS IN SECTION IV.

a. REFERENCE CODE. The code scheme recorded in column 6, Section II.

b. REMARKS. This column lists information pertinent to the maintenance function-being performed as indicated on the MAC, Section II.

Section II. MAINTENANCE ALLOCATION CHART

(1) Group Number	(2) Component/Assembly	(3) Maintenance Function	4 Maintenance Level					(5) Tools and Equipment	(6) Remarks
			C	O	F	H	D		
01	EVAPORATOR FAN SECTION								
0101	Covers, Panels and Frame	Inspect Repair Replace		0.5 1.0 0.5					
0102	Fan Housings and Fans	Inspect Repair Replace		1.0 1.5 2.0					
0103	Fan Motor	Inspect Test Replace		0.5 0.5 2.5					
02	EVAPORATOR COIL SECTION								
0201	Covers, Panels and Frame	Inspect Repair Replace		0.5 1.0 0.5					
0202	Valve, Expansion	Inspect Adjust Replace			0.5 2.0 4.0				
0203	Coil, Evaporator	Inspect Service Replace		0.5 1.0	8.0				
0204	Filter, Air	Inspect Service Replace		0.2 0.5 0.2					
03	CONDENSER FAN SECTION								
0301	Covers, Panels and Frame	Inspect Repair Replace		0.5 1.0 0.5					
0302	Control Panel and Controls	Inspect Repair Replace		0.5 0.5 0.7					

MAINTENANCE ALLOCATION CHART (Cont.)

(1) Group Number	(2) Component/Assembly	(3) Maintenance Function	(4) Maintenance Level					(5) Tools and Equipment	(6) Remarks
			C	O	F	H	D		
0303	Fan Housings and Fans	Inspect Repair Replace		1.0 1.5 2.0					
0304	Fan Motor	Inspect Test Replace		0.5 0.5 2.5					
0305	Filter Drier	Replace			4.0				
0306	Sight Glass	Inspect Replace		0.2	4.0				
04	CONDENSER COIL SECTION								
0401	Covers, Panels and Frame	Inspect Repair Replace		0.5 1.0 0.5					
0402	Coil, Condenser and Tubes	Inspect Service Replace		0.5 1.0	10.0				
05	COMPRESSOR SECTION								
0501	Covers, Panels and Frame	Inspect Repair Replace		0.5 1.0 0.5					
0502	Motor Compressor Assembly	Inspect Replace		0.5	8.0				
0503	Motor and Compressor	Test Repair			1.0 12.0				
0504	Switch, High Pressure	Inspect Adjust Replace		0.5	1.0 1.0				
0505	Electrical Contactor	Inspect Repair Replace		0.5 0.5 0.5					

**APPENDIX C**

**Section III.**

**TOOL AND TEST EQUIPMENT REQUIREMENTS**

**MAINTENANCE ALLOCATION CHART**

(1) Refer- ence Code	(2) Mainten- ance Level	(3) Nomenclature	(4) National/NATO stock number	(5) Tool number
	F-H	<p>No special tools and test equipment required. Standard tools and test equipment in the following kits are adequate to accomplish the maintenance functions listed in Section II:</p> <p>Recovery and Recycling Unit, Refrigerant</p> <p>Tool kit, service, refrigeration Unit (SC 5180-90-CL-N18)</p> <p>Soldering Gun Kit</p>	<p>4130-01-338-2707</p> <p>5180-00-597-1474</p> <p>3439-00-930-1639</p>	<p>17500B (07295)</p>

APPENDIX D

EXPENDABLE SUPPLIES AND MATERIALS LIST

Section I. Introduction

D-1. SCOPE.

This appendix lists expendable supplies and materials you will need to operate and maintain the Air Conditioner. These items are authorized to you by CTA50-970, Expendable Items (except Medical, Class V, Repair Parts, and Heraldic Items).

D-2. EXPLANATION OF COLUMNS.

a. COLUMN 1, ITEM NUMBER. This number is assigned to the entry in the listing and is referenced in the narrative instructions to identify the material (e.g., "Use cleaning compound, Item 5, App. D").

b. COLUMN 2, LEVEL. This column identifies the lowest level of maintenance that requires the listed item.

(enter as applicable):

C - Operator/Crew

F - Direct Support Maintenance

O - Organizational Maintenance

H - General Support Maintenance

c. COLUMN 3, NATIONAL STOCK NUMBER. This is the National Stock Number assigned to the item; use it to request or requisition the item.

d. COLUMN 4, DESCRIPTION. Indicates the Federal item name and, if required, a description to identify the item. The last line for each item indicates the part number followed by the Federal Supply Code for manufacturer (FSCM) in parenthesis, if applicable.

e. COLUMN 5, UNIT OF MEASURE (U/M). Indicates the measure used in performing the actual maintenance function. This measure is expressed by a two-character alphabetical abbreviation (e.g., ea, in, pr). If the unit of measure differs from the unit of issue, requisition the lowest unit of issue that will satisfy your requirements.

Section II. EXPENDABLE SUPPLIES AND MATERIALS LIST

---

(1)	(2)	(3)	(4)	(5)
ITEM NUMBER	LEVEL	NATIONAL STOCK NUMBER	DESCRIPTION	U / M
1	0	4130-00-860-0042	Coater, Air Filter, 1 Pint Container	EA
2	0	8040-00-664-0439	Adhesive, General Purpose, 1 Pint Container	EA

---



INDEX

Subject	A	Page No.
Adding Refrigerant . . . . .		4-6
Air Filter. . . . .		3-15
Assembly and Preparation for Use		
Assembly . . . . .		3-1
Installation . . . . .		3-1
Unpackaging . . . . .		3-1
C		
Capabilities and Features . . . . .		1-1
Charging the Refrigerant System with a Full Charge . . . . .		4-9
Compressor Motor Burnout		
General . . . . .		4-24
Minimm System Cleanout . . . . .		4-24
Compressor Section		
Cleaning . . . . .		3-27
Covers, Panels and Frame . . . . .		3-27
Inspection . . . . .		3-27
Installation . . . . .		3-29
Removal. . . . .		3-27
Repair . . . . .		3-29
Compoments of End Item List . . . . .		B-1
Condenser Coil Assembly		
General . . . . .		4-16
Inspection . . . . .		4-17
Installation . . . . .		4-17
Removal. . . . .		4-17
Condenser Coil Section		
Cleaning . . . . .		3-27
Covers, Panels and Frame . . . . .		3-25
Inspection . . . . .		3-27
Installation . . . . .		3-27
Removal. . . . .		3-25
Repair . . . . .		3-27
Condenser Coil and Tubes . . . . .		3-27
Condenser Fan Section		
Cleaning . . . . .		3-15
Covers, Panels and Frame . . . . .		3-15
Inspection . . . . .		3-16
Installation . . . . .		3-18
Removal. . . . .		3-15
Repair . . . . .		3-16
Control Panel and Controls		
Installation . . . . .		3-18
Removal. . . . .		3-18

INDEX

Subject Page No.

D

Difference Between Models . . . . . 1-2  
 Direct Support Maintenance. . . . . 4-1

E

Electrical Cent actor  
     Inspect . . . . . 3-29  
     Removal . . . . . 3-29  
     Repair . . . . . 3-29  
     Replace . . . . . 3-30  
 Equipmen Purpose. . . . . 1-1  
 Evacuating The Refrigerant System  
     Evacuating the High Side . . . . . 4-7  
     Evacuating the Low Side. . . . . 4-7  
     Evacuation of the System When Unit Has Lost Complete Charge . . . . . 4-9  
     General . . . . . 4-7  
 Evaporator Coil . . . . . 3-15  
 Evaporator Coil Assembly  
     General . . . . . 4-10  
     Inspection . . . . . 4-13  
     Installation . . . . . 4-13  
     Removal. . . . . 4-13  
     Replace . . . . . 4-13  
 Evaporator Coil Section  
     Cleaning . . . . . 3-15  
     Covers, Panels and Frame . . . . . 3-12  
     Inspection . . . . . 3-15  
     Installation . . . . . 3-15  
     Removal . . . . . 3-12  
     Repair . . . . . 3-15  
 Evaporator Fan Section  
     Cleaning . . . . . 3-7  
     Covers, Panels and Frame . . . . . 3-7  
     Inspection . . . . . 3-7  
     Removal . . . . . 3-7  
     Repair . . . . . 3-7  
 Expansion Valve  
     Adjust . . . . . 4-10  
     Inspect . . . . . 4-10  
     Repair . . . . . 4-10  
 Expendable Supplies and Materials List . . . . . D-1

F

Fan Housings and Fans (condenser)  
     Inspection . . . . . 3-21  
     Removal. . . . . 3-21  
     Repair . . . . . 3-21  
     Replace. . . . . 3-21

INDEX

Subject	Page No.
F	
Fan Housings and Fans (evaporator)	
Inspection . . . . .	3-11
Removal . . . . .	3-9
Repair . . . . .	3-11
Replace . . . . .	3-11
Fan Motor (condenser)	
Inspect . . . . .	3-25
Removal . . . . .	3-23
Replace . . . . .	3-25
Test. . . . .	3-25
Fan Motor (evaporator)	
Inspect . . . . .	3-12
Removal . . . . .	3-11
Replace . . . . .	3-12
Test . . . . .	3-12
Filter Drier	
General . . . . .	4-13
Installation . . . . .	4-16
Removal . . . . .	4-13
H	
Hand Receipt . . . . .	1-1
High Pressure Cutout Switch . . . . .	3-29, 4-25
Adjust . . . . .	4-25
General . . . . .	4-25
Installation . . . . .	4-25
Removal . . . . .	4-25
L	
Location and Description of Major Components . . . . .	1-2
M	
Maintenance Allocation Chart . . . . .	C-1
Maintenance Fores and Records . . . . .	1-1
Maintenance Procedures . . . . .	3-7, 4-1
Motor Compressor	
General. . . . .	4-23
Motor Compressor Assembly . . . . .	3-29,4-17
O	
Operating Instructions	
Description and Use of Operators' Controls and Indicators . . . . .	2-1
Operation Under Usual Conditions	
General. . . . .	2-3

INDEX

Subject	Page No.
0	
Operation . . . . .	2-3
Starting . . . . .	2-3
Stopping . . . . .	2-3
Operation Under Unusual Conditions	
Operation in Dusty or Sandy Areas . . . . .	2-4
Operation in Extreme Cold . . . . .	2-3
Operation in Extreme Heat . . . . .	2-4
Operation in Salt Water Areas . . . . .	2-4
Operation Under Rainy or Humid Conditions . . . . .	2-4
Organizational Maintenance Instructions	
Common Tools and Equipment . . . . .	3-1
Repair Parts . . . . .	3-1
Special Tools, TMDS, and Support Equipment . . . . .	3-1
P	
Performance Data . . . . .	1-2
Principles of Operation . . . . .	1-2
Preparation for Movement	
Extensive Movement . . . . .	3-3
Limited Movement . . . . .	3-3
Pressure Gages, Installation and Removal . . . . .	4-1
Preventive Maintenance Checks and Services	
Operator/Crew . . . . .	2-1
Organizational. . . . .	3-3
Pumping Down the Refrigerant System . . . . .	4-5
R	
References . . . . .	A-1
Refrigerant Sight Glass . . . . .	3-25, 4-16
General . . . . .	4-16
Installation . . . . .	4-16
Removal. . . . .	4-16
Refrigerant System . . . . .	4-1
Adding Refrigerant . . . . .	4-6
Charging the Refrigerant System With A Full Charge . . . . .	4-9
Evacuating the Refrigerant-System . . . . .	4-7
Opening The System . . . . .	4-6
Reporting Equipment Improvement Recommendations . . . . .	1-1
S	
Selector Switch	
Inspection. . . . .	3-20
Installation . . . . .	3-20
Removal. . . . .	3-18

INDEX

Subject	Page No.
<b>S</b>	
Service Upon Receipt	
Assembly . . . . .	3-1
Installation . . . . .	3-1
Unpackaging . . . . .	3-1
Sight Glass Assembly	
General . . . . .	4-16
Installation . . . . .	4-16
Removal . . . . .	4-16
<b>T</b>	
Temperature Control	
Inspection . . . . .	3-20
Installation . . . . .	3-20
Removal . . . . .	3-20
Troubleshooting . . . . .	3-3, 4-3



**By Order of the Secretary of the Army:**

**Official:**

**J. C. PENNINGTON**  
***Major General, United States Army***  
***The Adjutant General***

**E. C. MEYER**  
***General, United States Army***  
***Chief of Staff***

**DISTRIBUTION:**

To be distributed in accordance with DA Form 12-25C Operator Maintenance Requirements for Environmental Equipment Air Conditioners, 18,000 BTU, Floor Mounting.







# SOMETHING WRONG WITH THIS MANUAL?

THEN... JOT DOWN THE DOPE ABOUT IT ON THIS FORM, TEAR IT OUT, FOLD IT AND DROP IT IN THE MAIL!

FROM: (YOUR UNIT'S COMPLETE ADDRESS)

PFC JOHN DOE  
COA, 3<sup>rd</sup> ENGINEER BN  
FT. LEONARD WOOD MO 63108

DATE

PUBLICATION NUMBER

TM 5-4120-364-13

DATE

17 Oct 80

TITLE

Air Conditioner, Multi-Package,  
Type I Configuration, 18,000 BTU/HR

BE EXACT... PIN-POINT WHERE IT IS

IN THIS SPACE TELL WHAT IS WRONG AND WHAT SHOULD BE DONE ABOUT IT:

PAGE NO.	PARA-GRAPH	FIGURE NO.	TABLE NO.
6	2-1 a		
81		4-3	
125	line 20		

In line 6 of paragraph 2-1a the manual states the engine has 6 cylinders. The engine on my set only has 4 cylinders. Change the manual to show 4 cylinders.

Callout 16 on figure 4-3 is pointing at a bolt. In the key to fig. 4-3, item 16 is called a shim. Please correct one or the other.

Ordered a gasket, item 19 on figure B-16 by NSN 2910-00-762-3001. I got a gasket but it doesn't fit. Supply says I got what I ordered, so the NSN is wrong. Please give me a good NSN.

SAMPLE

TYPED NAME, GRADE OR TITLE, AND TELEPHONE NUMBER

JOHN DOE, PFC (268) 317-7111

SIGN HERE:

*John Doe*

DA FORM 2028-2  
1 AUG 74

P.S.--IF YOUR OUTFIT WANTS TO KNOW ABOUT YOUR MANUAL "FIND," MAKE A CARBON COPY OF THIS AND GIVE IT TO YOUR HEADQUARTERS.  
DRSTS-M Overprint 1, 1 Nov 78

TEAR ALONG DOTTED LINE

FILL IN YOUR  
UNIT'S ADDRESS

FOLD BACK

TEAR ALONG PERFORATED LINE

DEPARTMENT OF THE ARMY

\_\_\_\_\_  
\_\_\_\_\_

OFFICIAL BUSINESS  
PENALTY FOR PRIVATE USE \$300

POSTAGE AND FEES PAID  
DEPARTMENT OF THE ARMY  
DOD 314



COMMANDER  
US Army Troop Support and Aviation Materiel Readiness Command  
ATTN: DRSTS-MT 7  
4300 Goodfellow Boulevard  
St. Louis, MO 63120



# SOMETHING WRONG WITH THIS MANUAL?

THEN... JOT DOWN THE DOPE ABOUT IT ON THIS FORM, TEAR IT OUT, FOLD IT AND DROP IT IN THE MAIL!

FROM: (YOUR UNIT'S COMPLETE ADDRESS)

DATE

PUBLICATION NUMBER

TM 5-4120-364-13

DATE

17 Oct 80

TITLE

Air Conditioner, Multi-Package, Type I Configuration, 18,000 BTU/HR

BE EXACT... PIN-POINT WHERE IT IS

PAGE NO.	PARA-GRAPH	FIGURE NO.	TABLE NO.
----------	------------	------------	-----------

IN THIS SPACE TELL WHAT IS WRONG AND WHAT SHOULD BE DONE ABOUT IT:

TEAR ALONG DOTTED LINE

TYPED NAME, GRADE OR TITLE, AND TELEPHONE NUMBER

SIGN HERE:

FILL IN YOUR  
UNIT'S ADDRESS

FOLD BACK

DEPARTMENT OF THE ARMY

POSTAGE AND FEES PAID  
DEPARTMENT OF THE ARMY  
DOD-314

OFFICIAL BUSINESS

PENALTY FOR PRIVATE USE, \$300

Commander  
US Army Troop Support and Aviation  
Materiel Readiness Command  
ATTN: DRSTS-MTT  
4300 Goodfellow Boulevard  
St. Louis, MO 63120

TEAR ALONG DOTTED LINE

FOLD BACK

RECOMMENDED CHANGES TO EQUIPMENT TECHNICAL MANUALS



# SOMETHING WRONG WITH THIS MANUAL?

THEN... JOT DOWN THE DOPE ABOUT IT ON THIS FORM, TEAR IT OUT, FOLD IT AND DROP IT IN THE MAIL!

FROM: (YOUR UNIT'S COMPLETE ADDRESS)

DATE

IDENTIFICATION NUMBER: **TM 5-4120-364-13**

DATE: **17 Oct 60**

TITLE: **Air Conditioner, Multi-Package Type I Configuration, 18,000 BTU/HR**

BE EXACT... PIN-POINT WHERE IT IS				IN THIS SPACE TELL WHAT IS WRONG AND WHAT SHOULD BE DONE ABOUT IT:
PAGE NO.	PARA-GRAPH	FIGURE NO.	TABLE NO.	

TEAR ALONG DOTTED LINE

TYPED NAME, GRADE OR TITLE, AND TELEPHONE NUMBER

SIGN HERE:

DA FORM 2028-2  
1 AUG 74

P.S.--IF YOUR OUTFIT WANTS TO KNOW ABOUT YOUR MANUAL "FIND," MAKE A CARBON COPY OF THIS AND GIVE IT TO YOUR HEADQUARTERS.

FILL IN YOUR  
UNIT'S ADDRESS

FOLD BACK

DEPARTMENT OF THE ARMY

POSTAGE AND FEES PAID  
DEPARTMENT OF THE ARMY  
DOD-314

OFFICIAL BUSINESS

PENALTY FOR PRIVATE USE, \$300

Commander  
US Army Troop Support and Aviation  
Materiel Readiness Command  
ATTN: DRSTS-ITT  
4300 Goodfellow Boulevard  
St. Louis, MO 63120

TEAR ALONG DOTTED LINE

FOLD BACK

RECOMMENDED CHANGES TO EQUIPMENT TECHNICAL MANUALS



**SOMETHING WRONG WITH THIS MANUAL?**

THEN... JOT DOWN THE DOPE ABOUT IT ON THIS FORM, TEAR IT OUT, FOLD IT AND DROP IT IN THE MAIL!

FROM: (YOUR UNIT'S COMPLETE ADDRESS)

DATE

PUBLICATION NUMBER

DATE

TITLE

TM 5-4120-364-13

17 Oct 80

Air Conditioner, Multi-Package  
Type I Configuration, 18,000 BTU/HR

BE EXACT... PIN-POINT WHERE IT IS

IN THIS SPACE TELL WHAT IS WRONG AND WHAT SHOULD BE DONE ABOUT IT:

PAGE NO.

PARA-GRAPH

FIGURE NO.

TABLE NO.

TEAR ALONG DOTTED LINE

TYPED NAME, GRADE OR TITLE, AND TELEPHONE NUMBER

SIGN HERE:

DA FORM 2028-2  
1 AUG 74

P.S.--IF YOUR OUTFIT WANTS TO KNOW ABOUT YOUR MANUAL "FIND," MAKE A CARBON COPY OF THIS AND GIVE IT TO YOUR HEADQUARTERS.

FILL IN YOUR  
UNIT'S ADDRESS



DEPARTMENT OF THE ARMY

*Copy # 1*  
TM 5-4120-364-13

POSTAGE AND FEES PAID  
DEPARTMENT OF THE ARMY  
DOD-314

*Date Name*

OFFICIAL BUSINESS  
PENALTY FOR PRIVATE USE, \$300

iation

TEAR ALONG DOTTED LINE



# The Metric System and Equivalents

## Linear Measure

1 centimeter = 10 millimeters = .39 inch  
 1 decimeter = 10 centimeters = 3.94 inches  
 1 meter = 10 decimeters = 39.37 inches  
 1 dekameter = 10 meters = 32.8 feet  
 1 hectometer = 10 dekameters = 328.08 feet  
 1 kilometer = 10 hectometers = 3,280.8 feet

## Weights

1 centigram = 10 milligrams = .15 grain  
 1 decigram = 10 centigrams = 1.54 grains  
 1 gram = 10 decigrams = .035 ounce  
 1 dekagram = 10 grams = .35 ounce  
 1 hectogram = 10 dekagrams = 3.52 ounces  
 1 kilogram = 10 hectograms = 2.2 pounds  
 1 quintal = 100 kilograms = 220.46 pounds  
 1 metric ton = 10 quintals = 1.1 short tons

## Liquid Measure

1 centiliter = 10 milliliters = .34 fl. ounce  
 1 deciliter = 10 centiliters = 3.38 fl. ounces  
 1 liter = 10 deciliters = 33.81 fl. ounces  
 1 dekaliter = 10 liters = 2.64 gallons  
 1 hectoliter = 10 dekaliters = 26.42 gallons  
 1 kiloliter = 10 hectoliters = 264.18 gallons

## Square Measure

1 sq. centimeter = 100 sq. millimeters = .155 sq. inch  
 1 sq. decimeter = 100 sq. centimeters = 15.5 sq. inches  
 1 sq. meter (centare) = 100 sq. decimeters = 10.76 sq. feet  
 1 sq. dekameter (are) = 100 sq. meters = 1,076.4 sq. feet  
 1 sq. hectometer (hectare) = 100 sq. dekameters = 2.47 acres  
 1 sq. kilometer = 100 sq. hectometers = .386 sq. mile

## Cubic Measure

1 cu. centimeter = 1000 cu. millimeters = .06 cu. inch  
 1 cu. decimeter = 1000 cu. centimeters = 61.02 cu. inches  
 1 cu. meter = 1000 cu. decimeters = 35.31 cu. feet

## Approximate Conversion Factors

To change	To	Multiply by	To change	To	Multiply by
inches	centimeters	2.540	ounce-inches	newton meters	.007062
feet	meters	.305	centimeters	inches	.394
yards	meters	.914	meters	feet	3.280
miles	kilometers	1.609	meters	yards	1.094
square inches	square centimeters	6.451	kilometers	miles	.621
square feet	square meters	.093	square centimeters	square inches	.155
square yards	square meters	.836	square meters	square feet	10.764
square miles	square kilometers	2.590	square meters	square yards	1.196
acres	square hectometers	.405	square kilometers	square miles	.386
cubic feet	cubic meters	.028	square hectometers	acres	2.471
cubic yards	cubic meters	.765	cubic meters	cubic feet	35.315
fluid ounces	milliliters	29.573	cubic meters	cubic yards	1.308
pints	liters	.473	milliliters	fluid ounces	.034
quarts	liters	.946	liters	pints	2.113
gallons	liters	3.785	liters	quarts	1.057
ounces	grams	28.349	liters	gallons	.264
pounds	kilograms	.454	grams	ounces	.035
short tons	metric tons	.907	kilograms	pounds	2.205
pound-feet	newton-meters	1.365	metric tons	short tons	1.102
pound-inches	newton-meters	.11375			

## Temperature (Exact)

°F	Fahrenheit temperature	5/9 (after subtracting 32)	Celsius temperature	°C
----	------------------------	----------------------------	---------------------	----

